

Note:

Materials:

- .Plunger: Brass 0.25um Au over Ni
- .Barrel: Brass 0.25um Au over Ni
- .Spring: SUS surface treatment

Mechanical:

- .Contact force: 50g±20g at 1.0mm working stroke
- .Full stroke: 1.1mm
- .Life test: 20,000 cycles

Electrical:

- .Rated current & voltage: DC 12V; 1A
- .Contact resistance: 50 milliohm Max.

Cannot be used as the charging,

To ensure the best usage, please operate it based on the working height.
Based on the engineering drawings, shall not exceed the maximum allowed compression.



Approve Sign

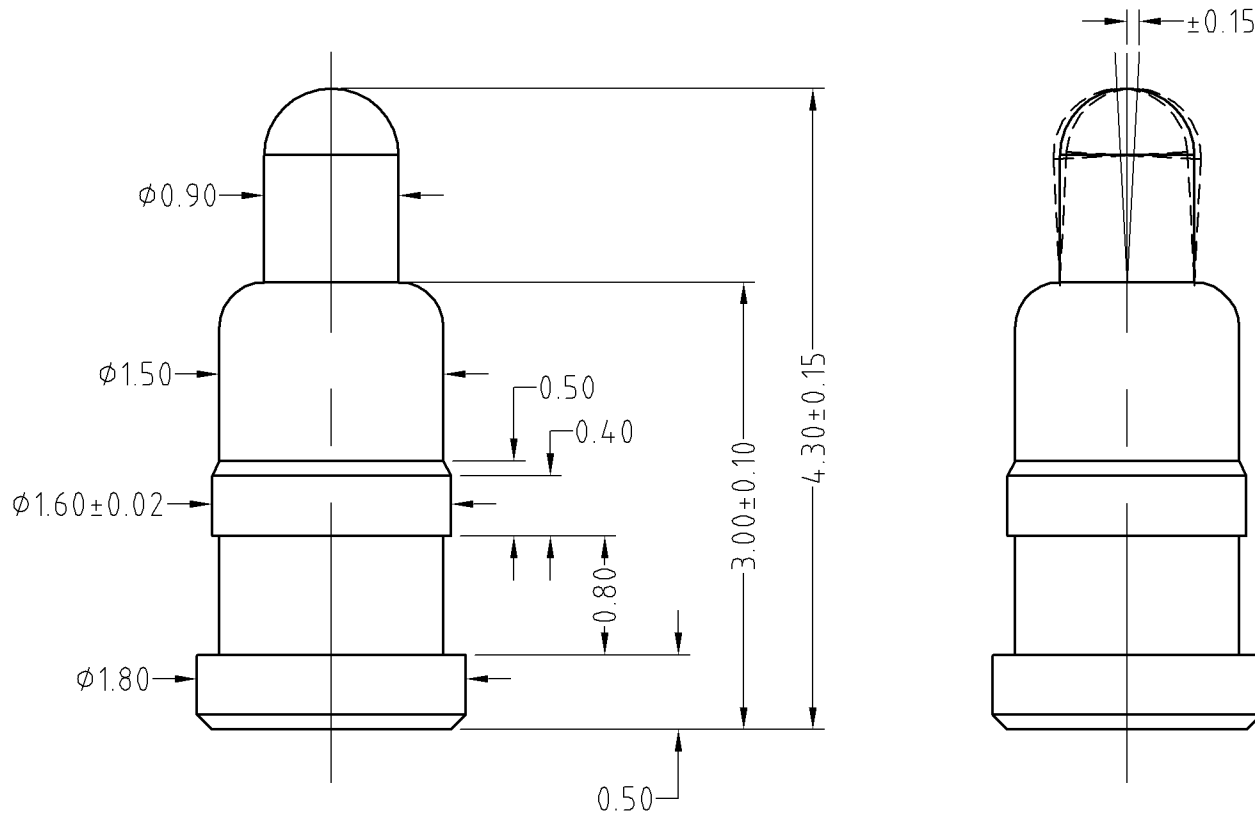

| BOM | | |
|---------|------------|-----|
| Part | NO. | Qty |
| Plunger | B001-P1010 | 1 |
| Barrel | B001-B1010 | 1 |
| Spring | B001-S1001 | 1 |

| | | | | |
|--|---------------|---------|--|--------------------|
| SCALE | 10:1 | UNIT:mm | THIS DOCUMENT IS THE SOLE PROPERTY OF CFE CORPORATION CO.,LTD., AND SHOULD NOT BE USED IN WHOLE OR IN PART WITHOUT PRIOR WRITTEN PERMISSION. | |
| ANGEL | $\pm 1^\circ$ | A4 | CFE 东莞市川富电子有限公司 CFE CORPORATION CO.,LTD. | |
| 0-6 | ± 0.05 | | SHEET: 1 of 1 | |
| 6-30 | ± 0.10 | DRAW | PART NO. | BF00111 |
| 30-150 | ± 0.15 | CHECK | FILE NAME | BF00111 |
| GENERAL TOLERANCE UNLESS OTHERWISE NOTED | | APPRO | TITLE. | Pogo pin connector |

| | | | |
|--------------|------|-------------|-----|
| ECN(DCN) NO. | D0 | 2015.05.11 | NEW |
| REV | DATE | DESCRIPTION | |

样品图纸