

HSF 禁止使用1级环境管理物质

Approve Sign

Note:

Materials:

- .Plating Plunger: 80u" Au over 50u" Min. Tin-copper-nickel alloy.
- .Plating Barrel: 200u" Au over 50u" Min. Tin-copper-nickel alloy.
- .Plating Spring: 4u" Au over 50u" Min. Ni

Mechanical:

- .Contact force: 100g±25g with 0.9mm working stroke
- .Full stroke: 1.5mm stroke
- .Life test: 10,000 cycles

Electrical:

- .Rated current & voltage: DC12V; 1A
- .Contact resistance: 50 milliohm Max.

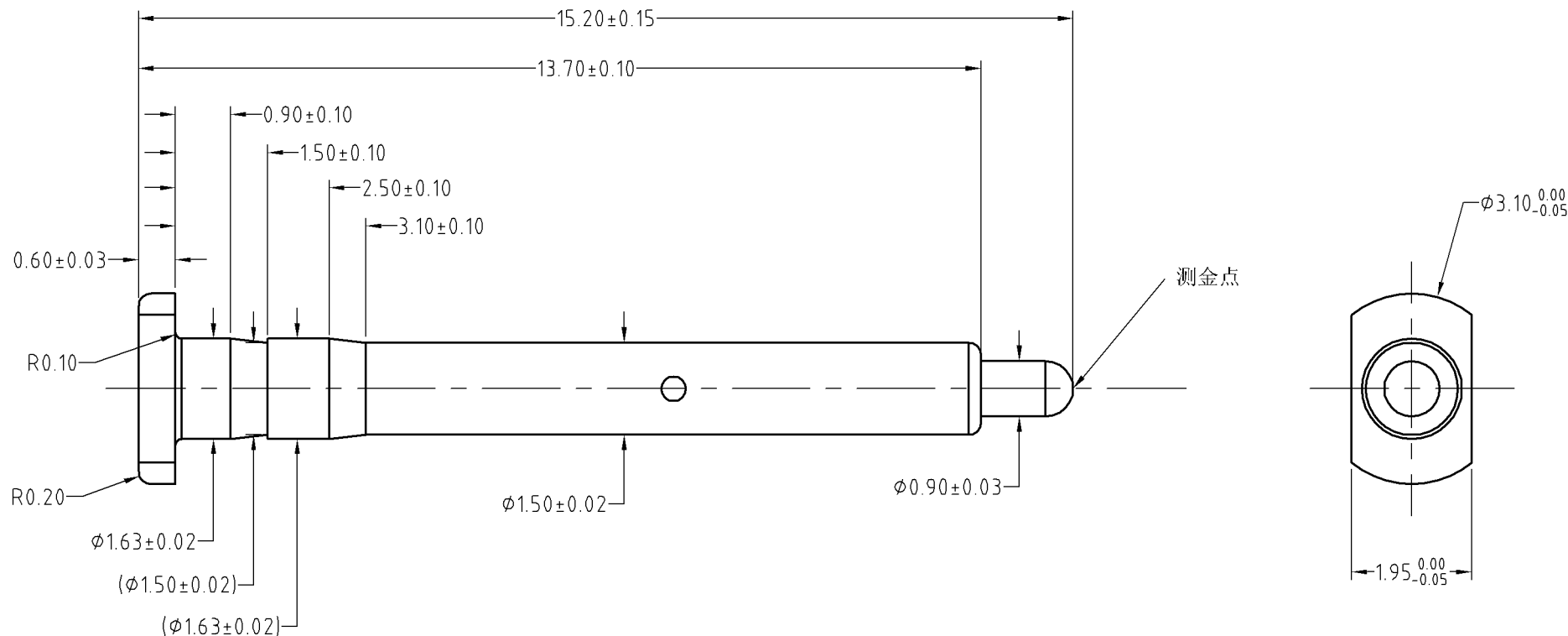

SCALE	10:1	UNIT:mm	THIS DOCUMENT IS THE SOLE PROPERTY OF CFE CORPORATION CO.,LTD., AND SHOULD NOT BE USED IN WHOLE OR IN PART WITHOUT PRIOR WRITTEN PERMISSION.	
ANGEL	±1°	A4	SHEET: 1 of 1	
0.000	±0.02		PART NO. BF00217	
0.00	±0.05	DRAW	FILE NAME BF00211	
0.0	±0.10	CHECK	TITLE. Pogo pin connector	
GENERAL TOLERANCE UNLESS OTHERWISE NOTED	APPRO			

CFE 东莞市川富电子有限公司
CFE CORPORATION CO.,LTD.

ECN(DCN) NO.	REV	DATE	DESCRIPTION	CHANGE	APPRO
	A0	2013.07.24	NEW		