

HSF 禁止使用1級環境管理物質

Approve Sign

Note:

1.Mechanical demands

1.Contact force: 120g±30g at 1.0mm working stroke

2.Plating plunger: Brass 15u" Au over 50u" Ni.

Plating barrel: Brass 15u" Au over 50u" Ni.

2.Inspection(working stroke)

1.Rated current & voltage: DC12V; 3A

2.Life test: 20,000 cycles

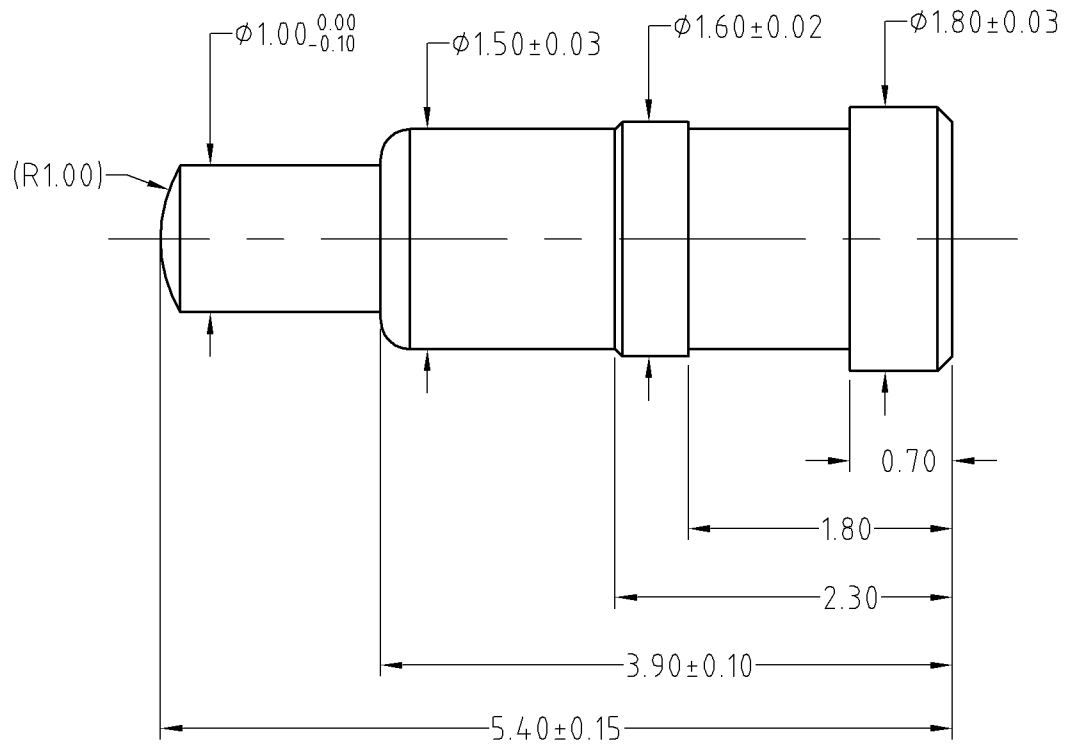

SCALE	10:1	UNIT:mm	THIS DOCUMENT IS THE SOLE PROPERTY OF CFE CORPOPATION CO.,LTD., AND SHOULD NOT BE USED IN WHOLE OR IN PART WITHOUT PRIOR WRITTEN PERMISSION.	川富科技股份有限公司 CFE CORPOPATION CO.,LTD.	
ANGEL	±1°	A4			
0.000	±0.02		SHEET: 1 of 1	PART NO.	BF03511
0.00	±0.05	DRAW		FILE NAME	BF03511
0.0	±0.10	CHECK		TITLE	Pogo pin connector
GENERAL TOLERANCE UNLESS OTHERWISE NOTED		APPRO			

ECN(DCN) NO.	D0	2012.08.23	NEW	CHANGE	APPRO
REV	DATE	DESCRIPTION			