

HSF 禁止使用1级环境管理物质

Approve Sign

Note:

- 1.Mechanical demands
 - 1.Contact force: 110g±20% at working height
 - 2.Plating plunger: Brass 1u" Au over 50u" Ni.
 - Plating barrel: Brass 1u" Au over 50u" Ni.
 - Plating spring: SUS304 1u" Au
- 3.Inspection(working height)
 - 1.Rated current & voltage: DC12V; 1A
 - 2.Life test: 20,000 cycles
 - 3.Contact resistance: 50 mohm Max.

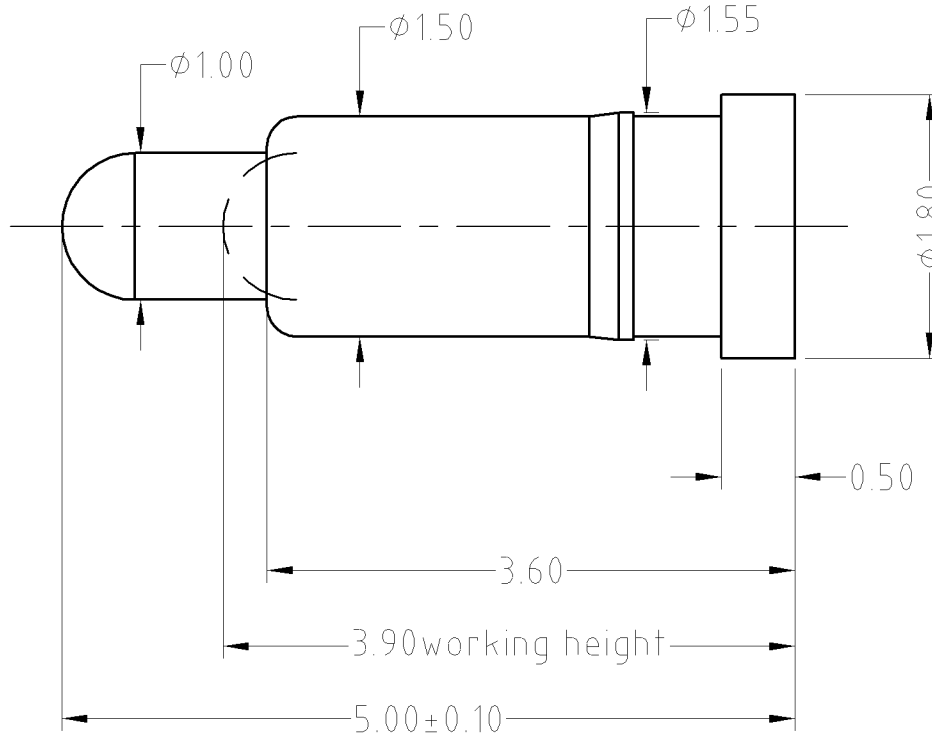

SCALE	10:1	UNIT:mm	THIS DOCUMENT IS THE SOLE PROPERTY OF CFE CORPORATION CO.,LTD., AND SHOULD NOT BE USED IN WHOLE OR IN PART WITHOUT PRIOR WRITTEN PERMISSION.	川富科技股份有限公司 CFE CORPORATION CO.,LTD. E:\QQ\川富科技01.jpg				
ANGEL	$\pm 1^\circ$	A4						
0.000	± 0.02					SHEET: 1 of 1		
0.00	± 0.05	DRAW					PART NO.	BF04711
0.0	± 0.10	CHECK					FILE NAME	BF04711
GENERAL TOLERANCE UNLESS OTHERWISE NOTED		APPRO		TITLE.	Pogo pin connector			

ECN(DCN) NO.	REV	DATE	DESCRIPTION	CHANGE	APPRO
	D0	2013.05.30	NEW		