

HSF 禁止使用1级环境管理物质

Approve Sign

Note:

1.Mechanical demands

- .Contact force: 70g±20g at working stroke
- .Plating plunger: Brass 15u" Au over 50u" Ni.
- .Plating barrel: Brass 5u" Au over 50u" Ni.

2.Inspection(working stroke)

- .Rated current & voltage: DC12V; 1A
- .Life test: 20,000 cycles

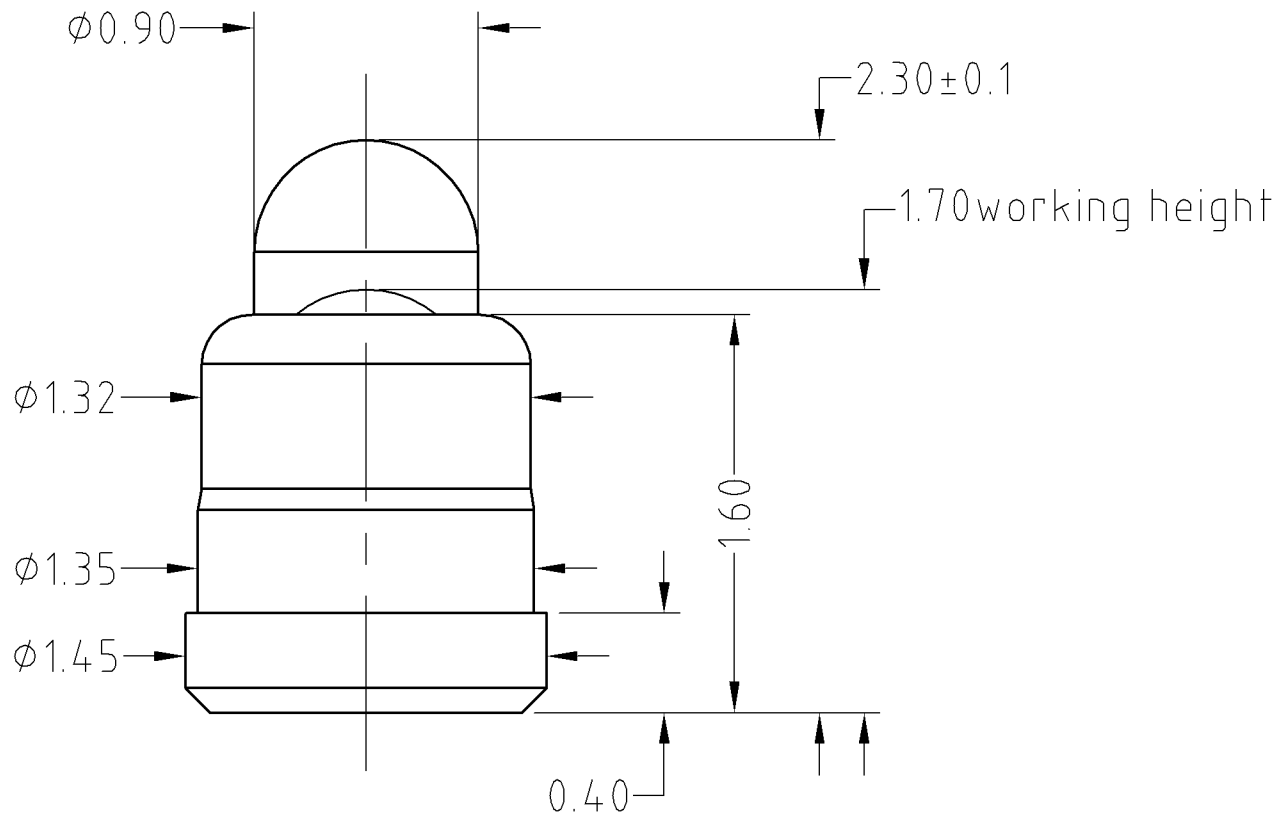

SCALE	10:1	UNIT:mm	THIS DOCUMENT IS THE SOLE PROPERTY OF CFE CORPORATION CO.,LTD., AND SHOULD NOT BE USED IN WHOLE OR IN PART WITHOUT PRIOR WRITTEN PERMISSION.	
ANGEL	$\pm 1^\circ$	A4	SHEET: 1 of 1	
0.000	± 0.02			
0.00	± 0.05	DRAW	PART NO.	BF04911
0.0	± 0.10	CHECK	FILE NAME	BF04911
GENERAL TOLERANCE UNLESS OTHERWISE NOTED	APPRO		TITLE.	Pogo pin connector

CFE 川富科技股份有限公司
CFE CORPORATION CO.,LTD.

ECN(DCN) NO.	D0	2013.05.30	NEW	CHANGE	APPRO
REV	DATE	DESCRIPTION	CHANGE	APPRO	