

HSF 禁止使用1级环境管理物质

To ensure the best usage, please operate it based on the working height.
Based on the engineering drawings, shall not exceed the maximum allowed compression.

Approve Sign

Note:

Materials:

.Plunger: Brass 5u" Pd-Ni over 51u" Ni.

.Barrel: Brass 5u" Pd-Ni over 51u" Ni.

.Spring: SUS

Mechanical:

.Contact force: 45g±10g at 4.0mm working height

.Life test: 20,000 cycles

Electrical:

.Rated current & voltage: DC 12V; 1A

.Contact resistance: 200 milliohm Max.

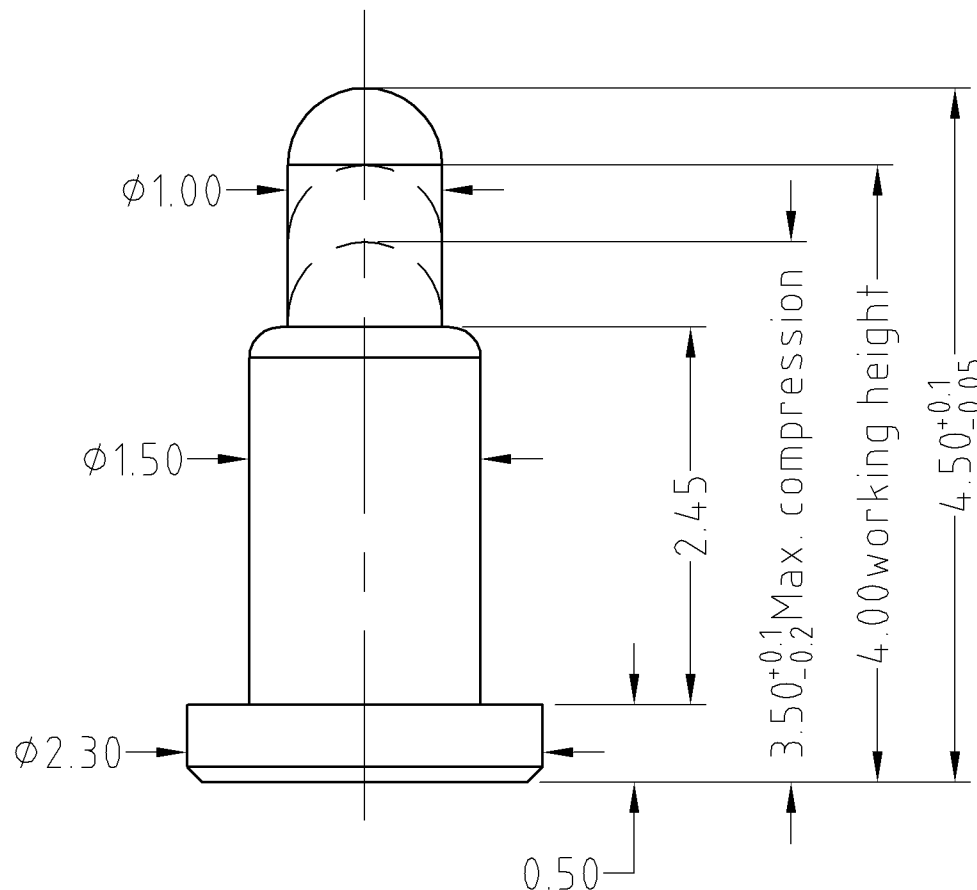

SCALE	10:1	UNIT:mm	THIS DOCUMENT IS THE SOLE PROPERTY OF CFE CORPORATION CO.,LTD., AND SHOULD NOT BE USED IN WHOLE OR IN PART WITHOUT PRIOR WRITTEN PERMISSION.	
ANGEL	±1°	A4	SHEET: 1 of 1	
	±0.02		PART NO. BF05721	
	±0.05	DRAW	FILE NAME BF05711	
	±0.10	CHECK	TITLE. Pogo pin connector	
GENERAL TOLERANCE UNLESS OTHERWISE NOTED		APPRO		

CFE 东莞市川富电子有限公司
CFE CORPORATION CO.,LTD.

ECN(DCN) NO.	REV	DATE	DESCRIPTION	CHANGE	APPRO
	D0	2013.08.21	NEW		