

HSF 禁止使用1級環境管理物質

Note:

1.Mechanical demands

- 1.Contact force: 120g±20% at working stroke
- 2.Plating plunger: Brass 1u" Au over 50~100u" Ni.
- Plating barrel: Brass 1u" Au over 50~100u" Ni.

2.Inspection

- 1.Rated current & voltage: DC12V; 1A
- 2.Life test: 20,000 cycles
- 3.Contact resistance: 50 mohm Max.(working height)

Approve Sign

工作行程3.5mm
彈力越大越好

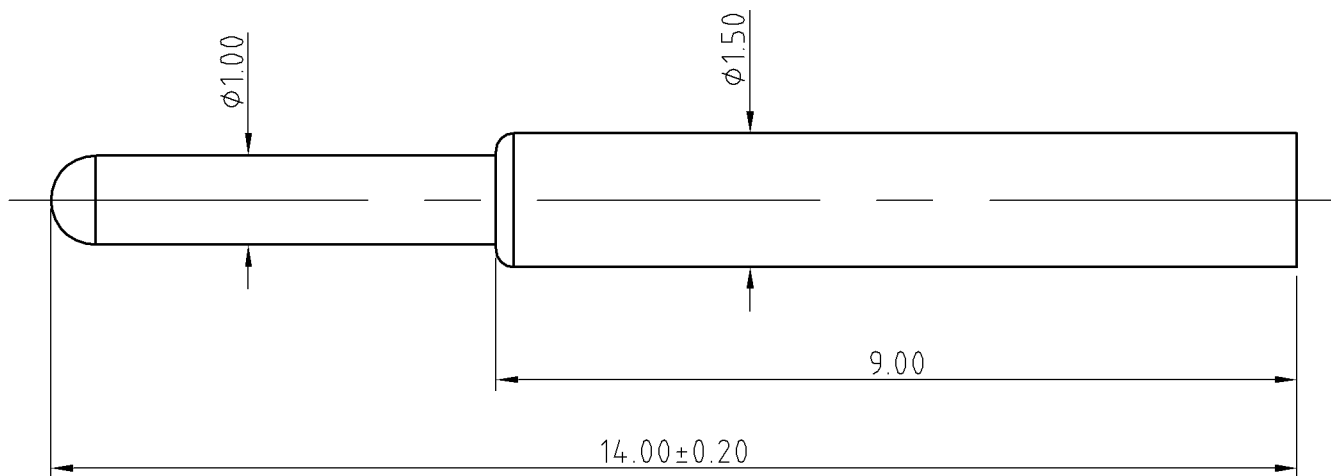

E:\001\?????.jpg

川富科技股份有限公司
CFE CORPOPATION CO., LTD.

Angle	±1°	MAT'L	
0.0000	±0.01	COLOR	
0.000	±0.02	DRAW	
0.00	±0.05	DESIGN	
0.0	±0.10	CHECK	

TITLE.

Pogo pin

PART NO.

BF05811

FILE NAME

BF05811

	D0	2012.08.23	NEW		
ECN(DCN) NO.	REV	DATE	DESCRIPTION	CHANGE	APPRO

GENERAL TOLERANCE
UNLESS OTHERWISE NOTED

APPRO

SCALE

1:1

UNIT:mm

A4

SHEET: 1 of 1