

1

2

3

4

Note:

Materials:

.Plunger: Brass 10u" Au over 50u" Ni

.Barrel: Brass 4u" Au over 50u" Ni

.Spring: SUS 1u" Au

Mechanical:

.Contact force: 80g±30g at 1.0mm working stroke

.Max. stroke: 1.10mm

.Life test: 20,000 cycles

Electrical:

.Rated current & voltage: DC 12V; 1A

.Contact resistance: 50 milliohm Max.



Approve Sign

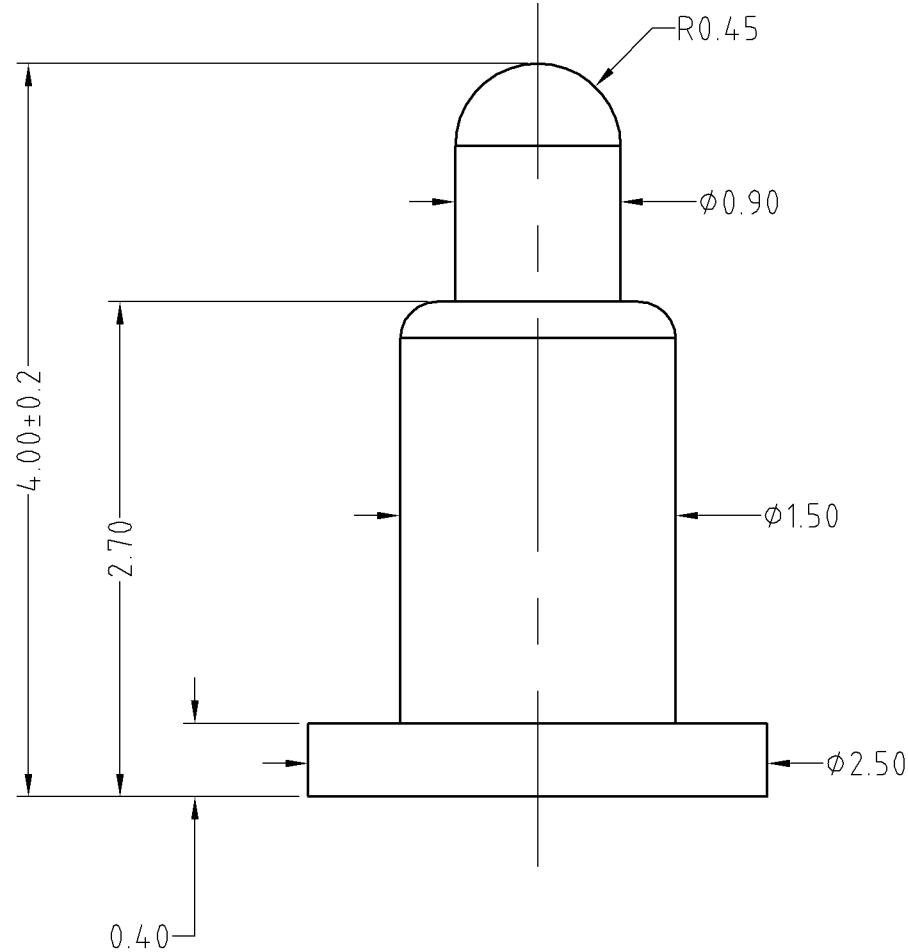

SCALE	10:1	UNIT:mm	THIS DOCUMENT IS THE SOLE PROPERTY OF CFE CORPORATION CO.,LTD., AND SHOULD NOT BE USED IN WHOLE OR IN PART WITHOUT PRIOR WRITTEN PERMISSION.	
ANGEL	±1°	A4	SHEET: 1 of 1	
0.000	±0.02		PART NO.	BF06311
0.00	±0.05	DRAW	FILE NAME	BF06311
0.0	±0.10	CHECK	TITLE	Pogo pin connector
GENERAL TOLERANCE UNLESS OTHERWISE NOTED		APPRO		



_____	D0	2013.07.06	NEW
ECN(DCN) NO.	REV	DATE	DESCRIPTION