

HSF 禁止使用1级环境管理物质

Approve Sign

Note:

1.Mechanical demands

- .Contact force: 95g±25g at working height
- .Plating plunger: Brass 5u" Pd-Ni over 50u" Ni.
- .Plating barrel: Brass 5u" Pd-Ni over 50u" Ni.

2.Inspection

- .Rated current & voltage: DC12V; 1A
- .Life test: 10,000 cycles
- .Contact resistance: 1000 milliohm Max.

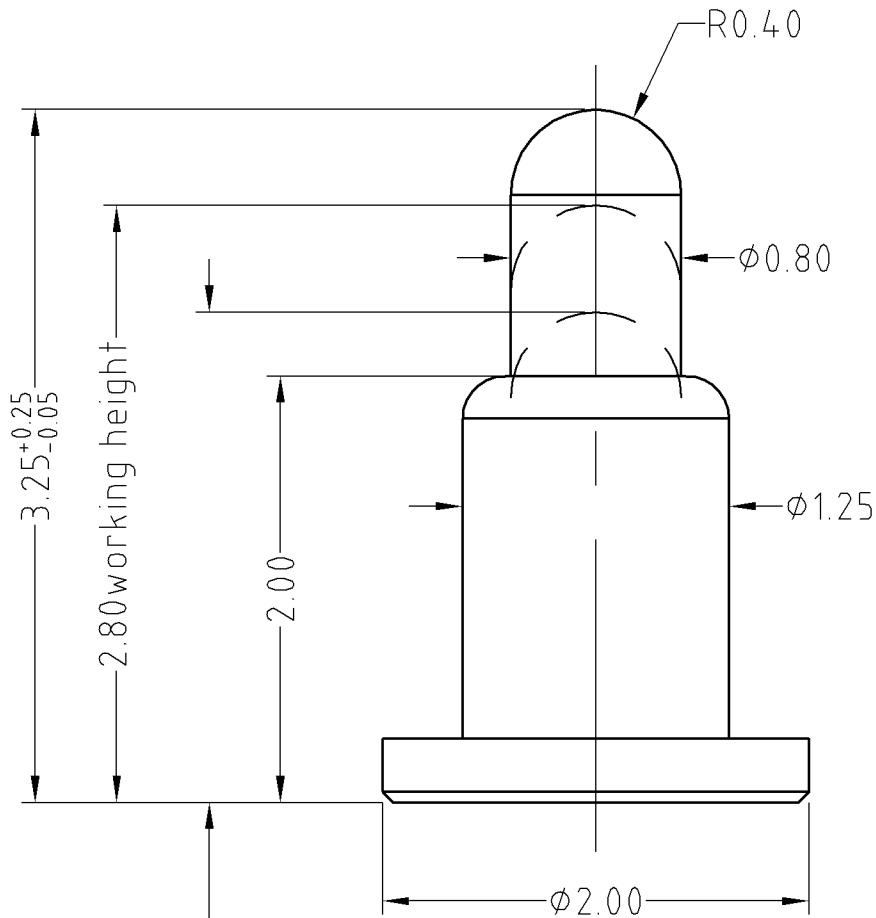

$2.30^{+0.1}_{-0.05}$  Max. compression

SCALE	10:1	UNIT:mm	THIS DOCUMENT IS THE SOLE PROPERTY OF CFE CORPORATION CO.,LTD., AND SHOULD NOT BE USED IN WHOLE OR IN PART WITHOUT PRIOR WRITTEN PERMISSION.	
ANGEL	$\pm 1^\circ$	A4	SHEET: 1 of 1	
	$\pm 0.02$		PART NO.	BF09711
	$\pm 0.05$	DRAW	FILE NAME	BF09711
	$\pm 0.10$	CHECK	TITLE	Pogo pin connector
GENERAL TOLERANCE UNLESS OTHERWISE NOTED	APPRO			

**CFE** 川富科技股份有限公司  
CFE CORPORATION CO.,LTD.

ECN(DCN) NO.	REV	DATE	DESCRIPTION	CHANGE	APPRO
	D0	2013.05.30	NEW		