

1

2

3

4

Note:

Materials:

.Plunger: Brass 10u" Au over 50u" Ni

.Barrel: Brass 10u" Au over 50u" Ni

.Spring: SUS

Mechanical:

.Contact force: 110g±20% at 2.60 working height

.Life test: 20,000 cycles

Electrical:

.Rated current & voltage: DC 12V; 1A Max.

.Contact resistance: 100 milliohm Max.

Approve Sign

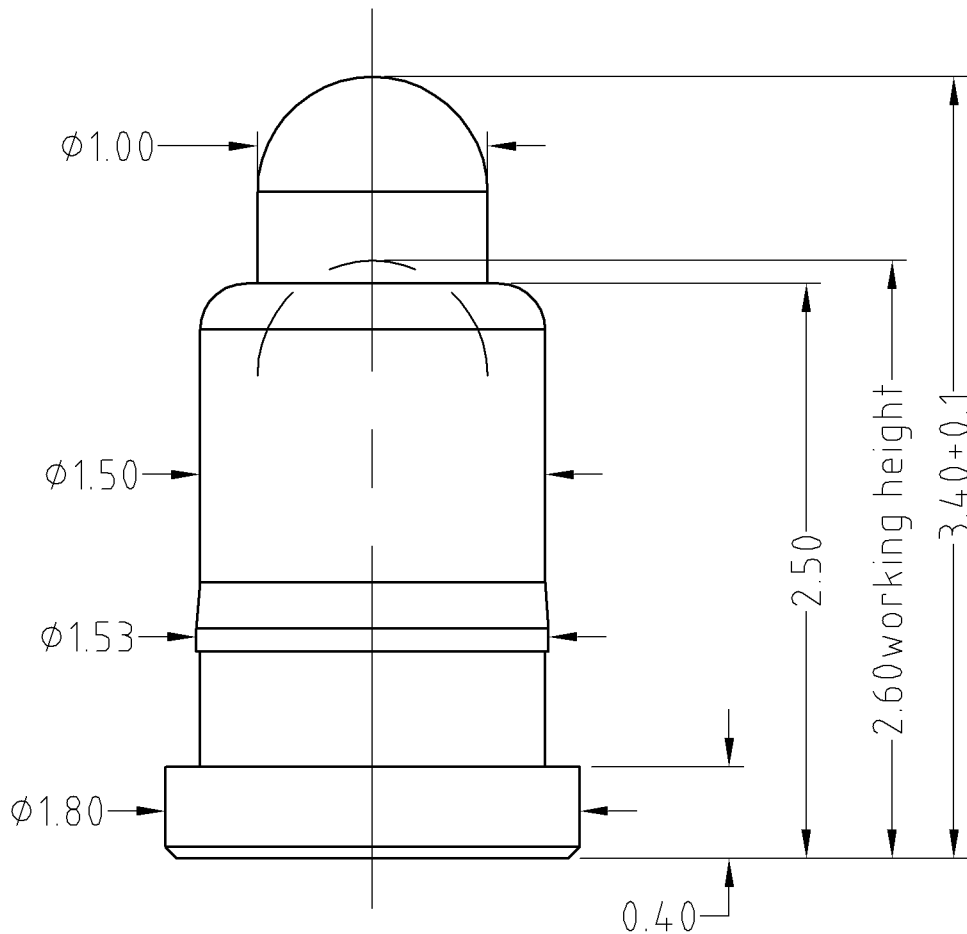

SCALE	10:1	UNIT:mm	THIS DOCUMENT IS THE SOLE PROPERTY OF CFE CORPORATION CO.,LTD., AND SHOULD NOT BE USED IN WHOLE OR IN PART WITHOUT PRIOR WRITTEN PERMISSION.	
ANGEL	±1°	A4	SHEET: 1 of 1	
0.000	±0.02		PART NO.	BF104.11
0.00	±0.05	DRAW	FILE NAME	BF104.11
0.0	±0.10	CHECK	TITLE.	Pogo pin connector
GENERAL TOLERANCE UNLESS OTHERWISE NOTED		APPRO		



	D0	2013.07.06	NEW
ECN(DCN) NO.	REV	DATE	DESCRIPTION