

1

2

3

4

HSF 禁止使用1级环境管理物质

Note:

Materials:

.Plunger: Brass 10u" Au over 50u" Ni

.Barrel: Brass 5u" Au over 50u" Ni

.Spring: SUS

Mechanical:

.Contact force: 60g±20g at 2.80 working height

.Life test: 20,000 cycles

Electrical:

.Rated current & voltage: DC 12V; 1A Max.

.Contact resistance: 50 milliohm Max.

A

B

C

D

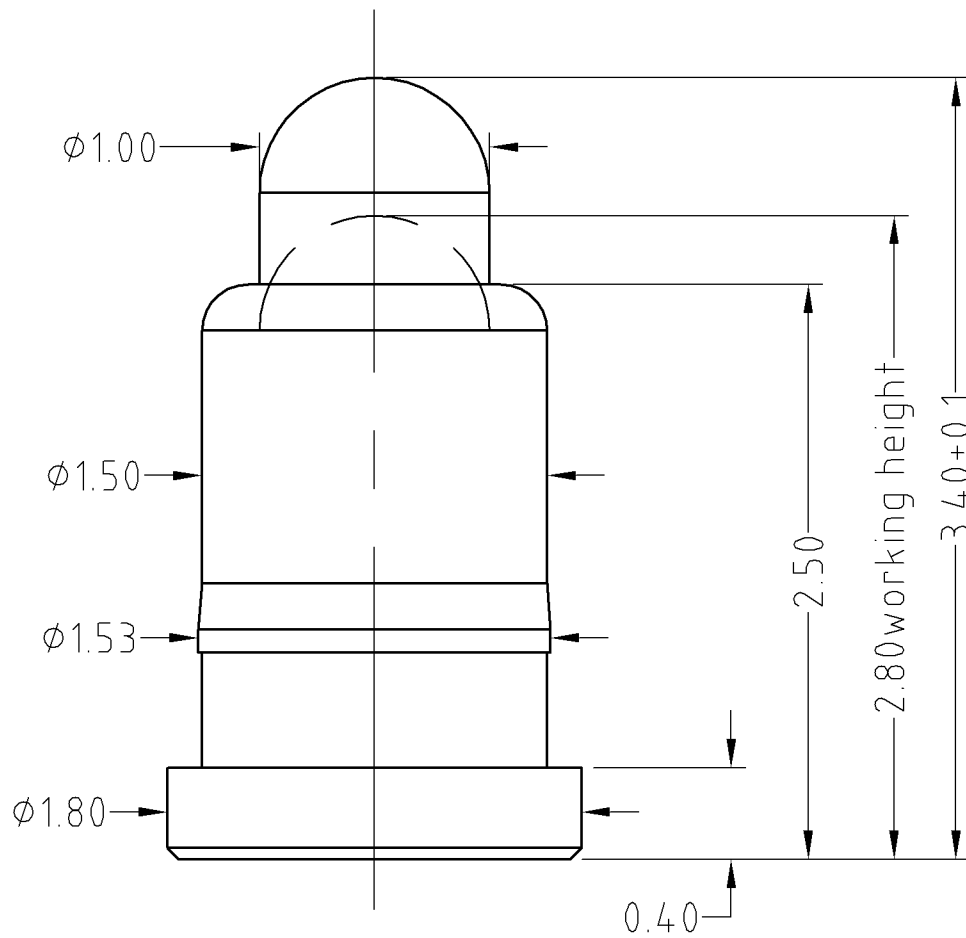

SCALE	10:1	UNIT:mm	THIS DOCUMENT IS THE SOLE PROPERTY OF CFE CORPORATION CO.,LTD., AND SHOULD NOT BE USED IN WHOLE OR IN PART WITHOUT PRIOR WRITTEN PERMISSION.	
ANGEL	$\pm 1^\circ$	A4	SHEET: 1 of 1	
0.000	± 0.02			
0.00	± 0.05	DRAW	PART NO.	BF10412
0.0	± 0.10	CHECK	FILE NAME	BF10411
GENERAL TOLERANCE UNLESS OTHERWISE NOTED	APPRO		TITLE	Pogo pin connector



ECN(DCN) NO.	REV	DATE	DESCRIPTION	CHANGE	APPRO
	D0	2013.07.06	NEW		