

HSF 禁止使用1级环境管理物质

To ensure the best usage, please operate it based on the working height.
Based on the engineering drawings, shall not exceed the maximum allowed compression.

Approve Sign

Note:

Materials:

- .Plunger: Brass 20u" Au over 50u" Ni
- .Barrel: Brass 10u" Au over 50u" Ni
- .Spring: SUS
- .Bead: Ceramic bead

Mechanical:

- .Contact force: 60g±20g at working height
- .Life test: 10,000 cycles

Electrical:

- .Rated current & voltage: DC 12V; 3A
- .withstand peak value 5A in 1s, flash with any function damage
- .Contact resistance: 50 milliohm Max.

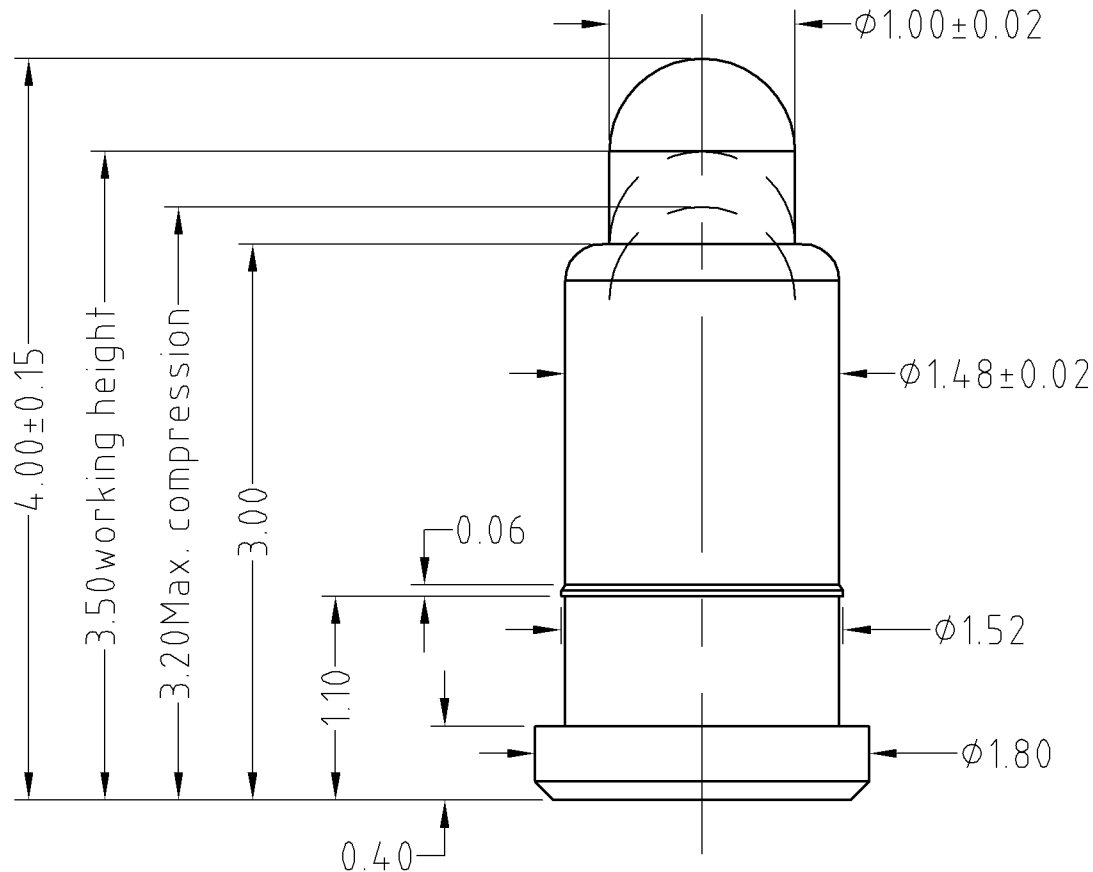
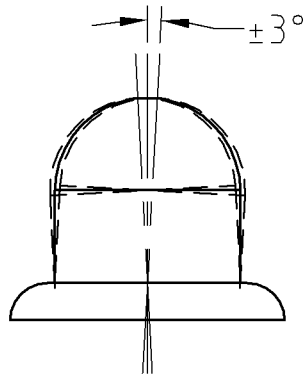

SCALE	10:1	UNIT:mm	THIS DOCUMENT IS THE SOLE PROPERTY OF CFE CORPORATION CO.,LTD., AND SHOULD NOT BE USED IN WHOLE OR IN PART WITHOUT PRIOR WRITTEN PERMISSION.	
ANGEL	±1°	A4	SHEET: 1 of 1	
0.000	±0.02		PART NO. BF10511	
0.00	±0.05	DRAW	FILE NAME BF10511	
0.0	±0.10	CHECK	TITLE. Pogo pin connector	
GENERAL TOLERANCE UNLESS OTHERWISE NOTED		APPRO		



ECN(DCN) NO.	REV	DATE	DESCRIPTION	CHANGE	APPRO
	D0	2013.08.02	NEW		