

HSF 禁止使用1级环境管理物质

To ensure the best usage, please operate it based on the working height.
Based on the engineering drawings, shall not exceed the maximum allowed compression.

Approve Sign

Note:

Materials:

.Plunger: Brass 15u" Au over Ni

.Barrel: Brass 15u" Au over Ni

.Spring: SUS Au

Mechanical:

.Contact force: 88g±20g at 0.7mm working stroke

.Life test: 50,000 cycles

Electrical:

.Rated current & voltage: DC 12V; 3A Max.

.Contact resistance: 50 milliohm Max.

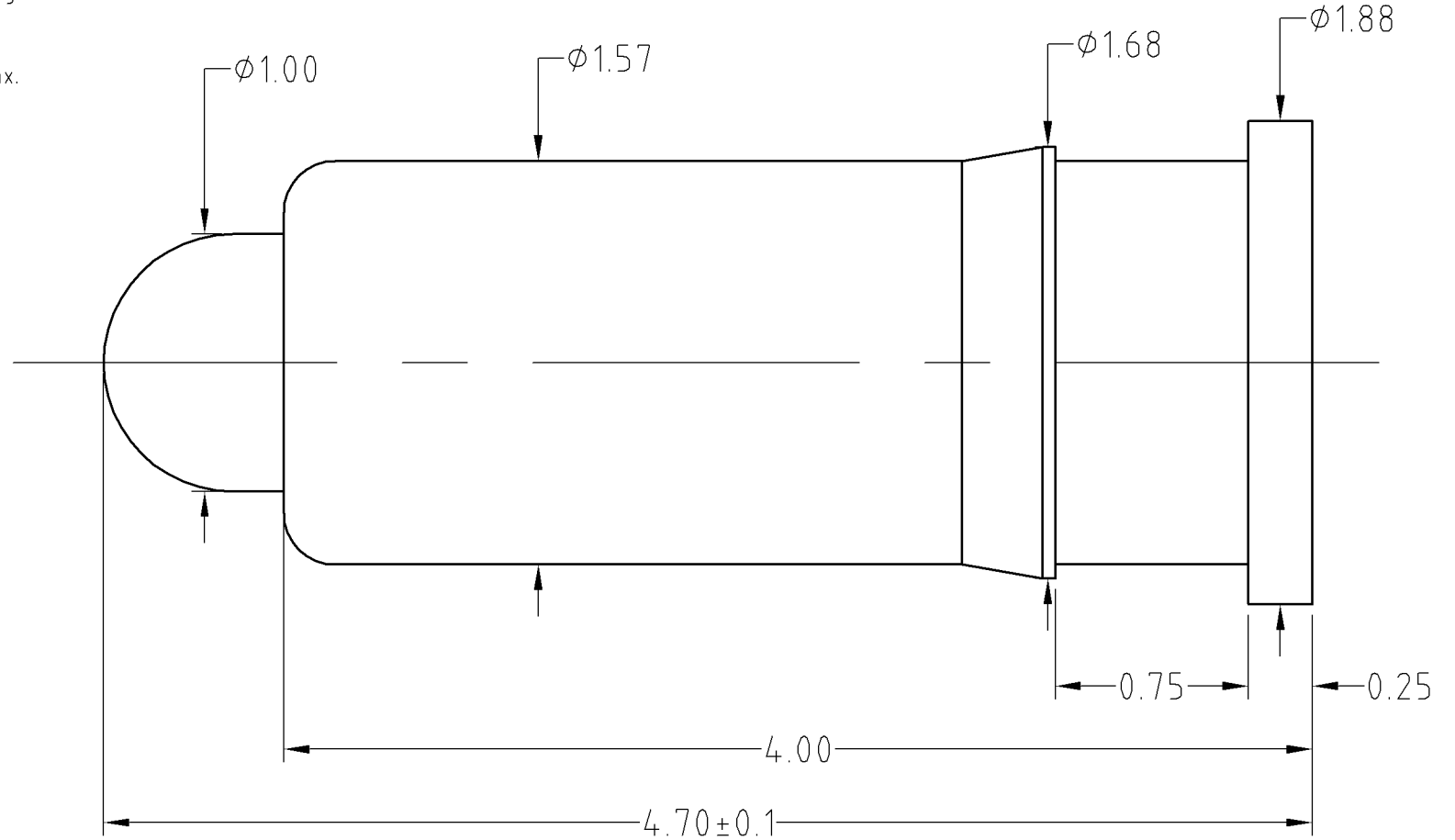

SCALE	10:1	UNIT:mm	THIS DOCUMENT IS THE SOLE PROPERTY OF CFE CORPORATION CO.,LTD., AND SHOULD NOT BE USED IN WHOLE OR IN PART WITHOUT PRIOR WRITTEN PERMISSION.	
ANGEL	±1°	A4	SHEET: 1 of 1	
0~6	±0.05			
6~30	±0.10	DRAW	PART NO.	BF11611
30~120	±0.15	CHECK	FILE NAME	BF11611
GENERAL TOLERANCE UNLESS OTHERWISE NOTED	APPRO		TITLE.	Pogo pin connector

CFE 东莞市川富电子有限公司
CFE CORPORATION CO.,LTD.

ECN(DCN) NO.	REV	DATE	DESCRIPTION	CHANGE	APPRO
	D0	2012.03.06	NEW		