

Note:

Materials:

- .Plunger: Brass 0.125um Au over Ni
- .Barrel: Brass 0.075um Au over Ni
- .Spring: SUS surface treatment

Mechanical:

- .Contact force: 100g±20g at 0.6mm working stroke
- .Life test: 30,000 cycles

Electrical:

- .Rated current & voltage: DC 12V; 1.0A
- .Contact resistance: 50 milliohm Max.

Cannot be used as the charging,

To ensure the best usage, please operate it based on the working height.  
Based on the engineering drawings, shall not exceed the maximum allowed compression.

A

B

C

D



Approve Sign

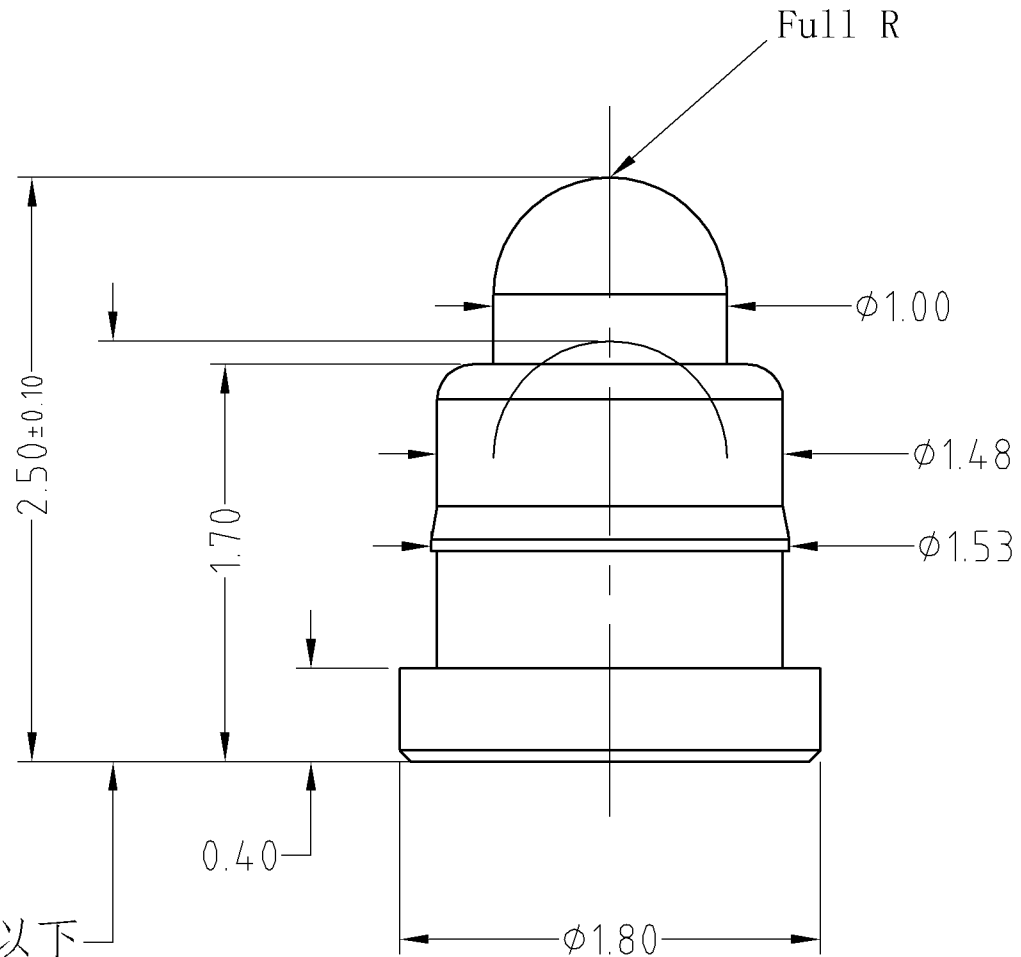

可压到1.80以下

BOM		
Part	NO.	Qty
Plunger	B385-P2005	1
Barrel	M601-B4003	1
Spring	M604-S1001	1

SCALE	10:1	UNIT:mm	THIS DOCUMENT IS THE SOLE PROPERTY OF CFE CORPORATION CO.,LTD., AND SHOULD NOT BE USED IN WHOLE OR IN PART WITHOUT PRIOR WRITTEN PERMISSION.	
ANGEL	±1°	A4	SHEET: 1 of 1	
0~6	±0.10			
6~30	±0.15	DRAW	PART NO.	BF38522
30~150	±0.20	CHECK	FILE NAME	BF385XX
GENERAL TOLERANCE UNLESS OTHERWISE NOTED		APPRO	TITLE.	Pogo pin connector



ECN(DCN) NO.	B0	2015.05.28	NEW
REV	DATE	DESCRIPTION	