

Note:

Materials:

.Plunger: Brass 0.25um Au over Ni

.Barrel: Brass 0.25um Au over Ni

.Spring: SUS surface treatment

Mechanical:

.Contact force: 50g±20g at 4.0mm working height

.Life test: 30,000 cycles

Electrical:

.Rated current & voltage: DC 12V; 1.0A

.Contact resistance: 50 milliohm Max.

To ensure the best usage, please operate it based on the working height.

Based on the engineering drawings, shall not exceed the maximum allowed compression.



Approve Sign

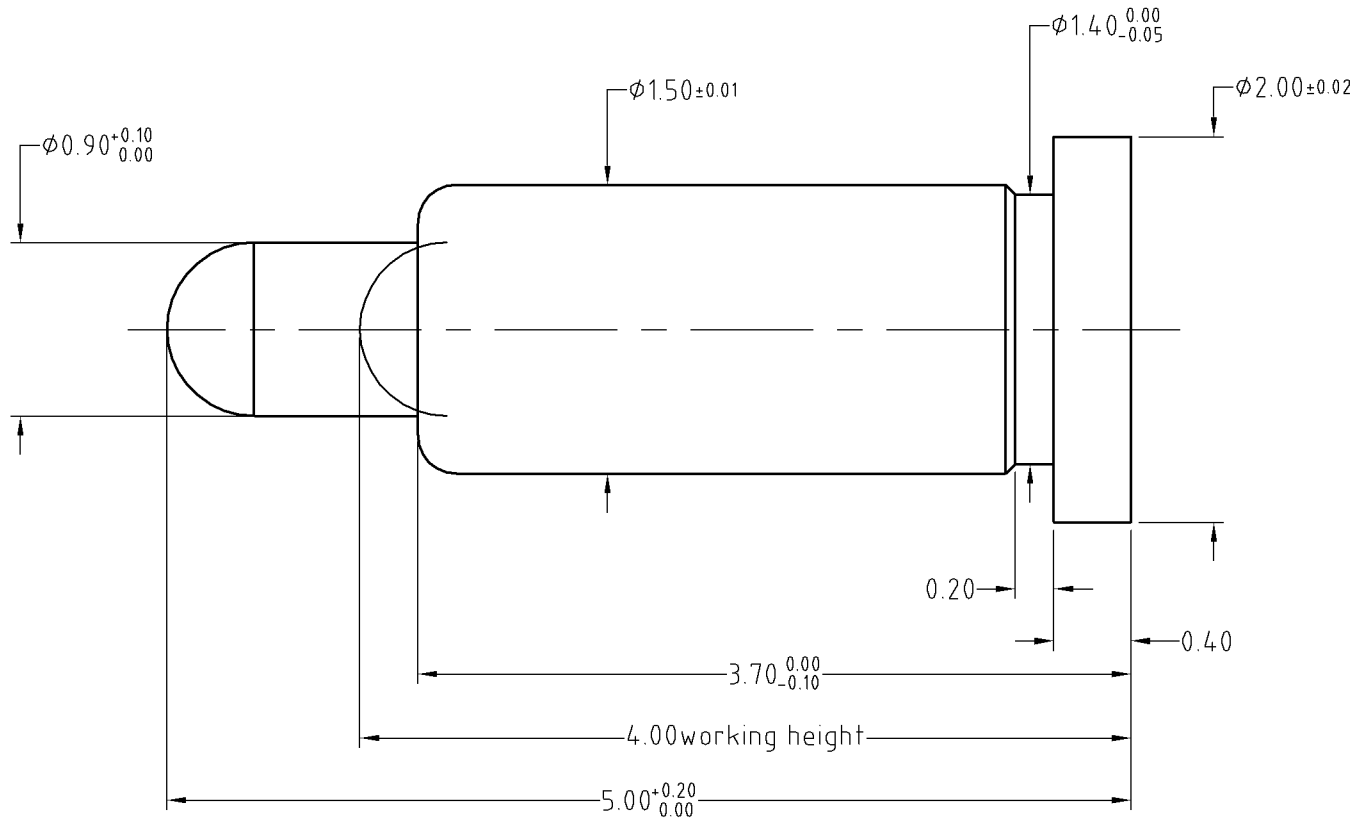

BOM		
Part	NO.	Qty
Plunger	B445-P1010	1
Barrel	B445-B1010	1
Spring	B445-S1001	1

SCALE	10:1	UNIT:mm	THIS DOCUMENT IS THE SOLE PROPERTY OF CFE CORPORATION CO.,LTD., AND SHOULD NOT BE USED IN WHOLE OR IN PART WITHOUT PRIOR WRITTEN PERMISSION.	CFE 东莞市川富电子有限公司 CFE CORPORATION CO.,LTD.	
ANGEL	±1°	A4			
0-6	±0.10		SHEET: 1 of 1	PART NO.	BF44511
6-30	±0.15	DRAW		FILE NAME	BF445XX
30-150	±0.20	CHECK		TITLE	Pogo pin connector
GENERAL TOLERANCE UNLESS OTHERWISE NOTED		APPRO			

_____	D0	2015.06.04	NEW
ECN(DCN) NO.	REV	DATE	DESCRIPTION