

Note:

Materials:

- .Insulator: Black high temperature plastics U194 V-0
- .Plunger: Brass Au over Ni.
- .Spring: SUS surface treatment
- .Barrel: Brass Au over Ni.

Mechanical:

- .Contact force: 70g±20g at 1.0mm working stroke
- .Full stroke: 1.4mm
- .Life test: 100,000 cycles

Electrical:

- .Rated current & voltage: DC12V;
- .Contact resistance: 50 milliohm Max.

Standard tolerances are:

- .Diameters: +/-0.05mm
- .Lengths: +/-0.15mm
- .Angles: +/-2°

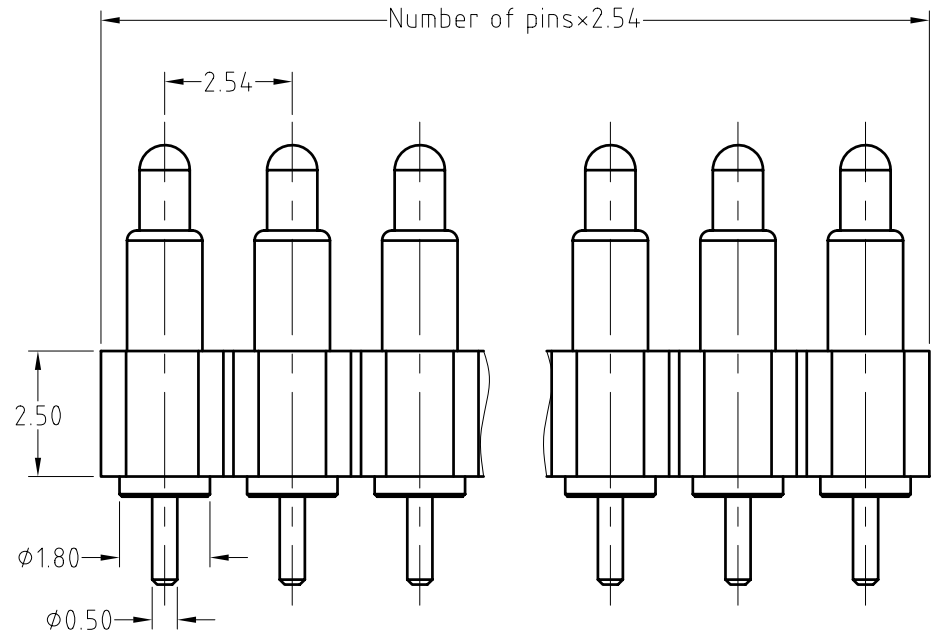
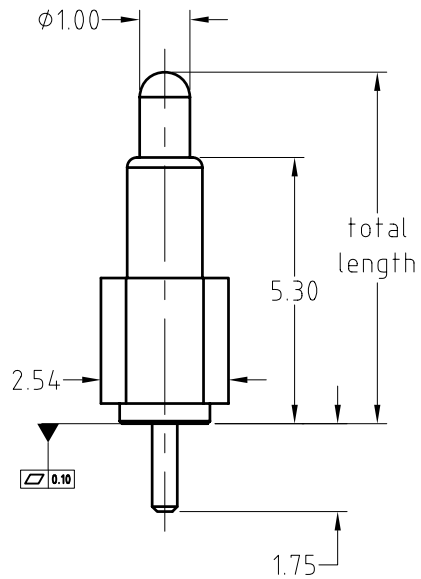

| MP315- SS GG | | | | |
|--------------|---------------|--------------|-------------|---------|
| SS | Rated current | Total length | GG-Plating: | |
| 11 | 5A Max. | 6.50mm | Barrel | Plunger |
| 21 | 5A Max. | 7.00mm | 1-5u" | 1-5u" |
| 31 | 5A Max. | 7.50mm | 2-10u" | 2-10u" |
| 41 | 5A Max. | 8.00mm | 3-15u" | 3-15u" |
| | | | 4-20u" | 4-20u" |

| Pogo pin Connector | | | | | Qty |
|--------------------|------------|------------|------------|------------|-----|
| MP315-SSGG-ANN100A | | | | | 1 |
| Pogo pin | MP315-11GG | MP315-21GG | MP315-31GG | MP315-41GG | NN |
| Insulator | H254-NNA01 | | | | 1 |

| SCALE | 10:1 | UNIT:mm | THIS DOCUMENT IS THE SOLE PROPERTY OF CFE CORPORATION CO.,LTD., AND SHOULD NOT BE USED IN WHOLE OR IN PART WITHOUT PRIOR WRITTEN PERMISSION. | |
|--|-------|---------|--|--|
| ANGEL | ±1° | A4 | SHEET: 1 of 1 | |
| 0~6 | ±0.05 | | | |
| 6~30 | ±0.10 | DRAW | | |
| 30~150 | ±0.15 | CHECK | | |
| GENERAL TOLERANCE UNLESS OTHERWISE NOTED | | APPRO | | |



PART NO. MP315-SSGG-ANN100A

FILE NAME 315

TITLE. Pogo pin connector

| ECN(DCN) NO. | REV | DATE | DESCRIPTION |
|--------------|-----|------------|-------------|
| | A0 | 2014.01.15 | NEW |