

HSF 禁止使用1级环境管理物质

Approve Sign

Note:

Materials:

- .Plunger: Brass 20u" Au over 50u" Ni
- .Barrel: Brass 15u" Au over 50u" Ni
- .Plating spring: SUS 1u" Au
- .Bead: Ceramic bead

Mechanical:

- .Contact force: 100g±20g at 0.8mm working stroke
- .Life test: 10,000 cycles

Electrical:

- .Rated current & voltage: DC 20V; 5A

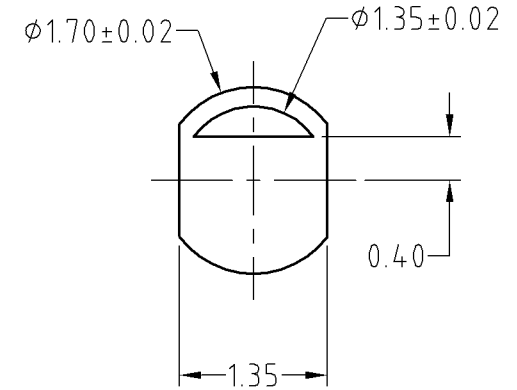
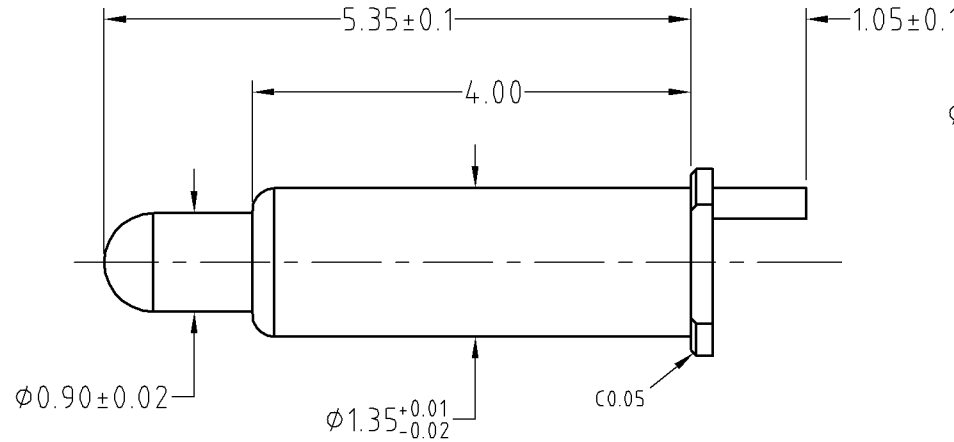
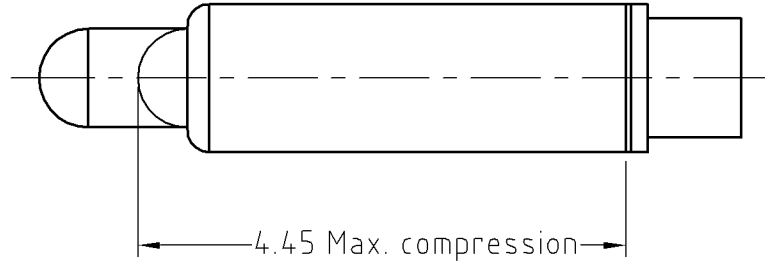

SCALE	10:1	UNIT:mm	THIS DOCUMENT IS THE SOLE PROPERTY OF CFE CORPORATION CO.,LTD., AND SHOULD NOT BE USED IN WHOLE OR IN PART WITHOUT PRIOR WRITTEN PERMISSION.
ANGEL	±1°	A4	
0.000	±0.02		
0.00	±0.05	DRAW	
0.0	±0.10	CHECK	
GENERAL TOLERANCE UNLESS OTHERWISE NOTED			APPRO

		东莞市川富电子有限公司 CFE CORPORATION CO.,LTD.	
PART NO.	BE03921	FILE NAME	BE03921
TITLE.	Pogo pin connector		

ECN(DCN) NO.	REV	DATE	DESCRIPTION	CHANGE	APPRO
	A0	2013.07.25	NEW		