

1

2

3

4

HSF 禁止使用1级环境管理物质

Approve Sign

Note:
 Materials:
 .Plunger: Brass 10u" Au over 50u" Ni
 .Barrel: Brass 15u" Au over 50u" Ni
 .Spring: SUS insulate coating
 Mechanical:
 .Contact force: 50g±20% at 0.7mm working stroke
 .Full stroke: 1.40mm
 .Life test: 20,000 cycles
 Electrical(working stroke):
 .Rated current & voltage: DC20V; 5A
 .Contact resistance: 50 milliohm Max.

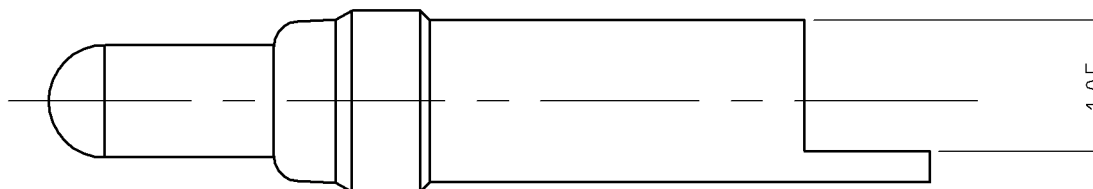
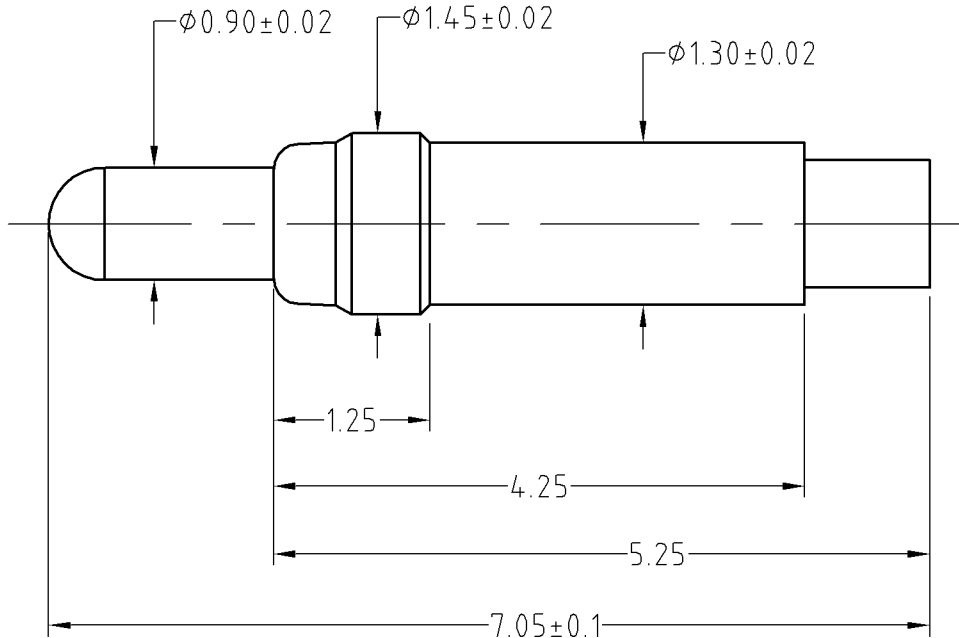

SCALE	10:1	UNIT:mm	THIS DOCUMENT IS THE SOLE PROPERTY OF CFE CORPORATION CO.,LTD., AND SHOULD NOT BE USED IN WHOLE OR IN PART WITHOUT PRIOR WRITTEN PERMISSION.	SHEET: 1 of 1	PART NO.	BE06711
ANGEL	±1°	A4				
0.000	±0.02					
0.00	±0.05	DRAW				
0.0	±0.10	CHECK				
GENERAL TOLERANCE UNLESS OTHERWISE NOTED	APPRO				TITLE.	Pogo pin connector

CFE 东莞市川富电子有限公司
 CFE CORPORATION CO.,LTD.

ECN(DCN) NO.	REV	DATE	DESCRIPTION	CHANGE	APPRO
	A0	2013.07.17	NEW		