

HSF 禁止使用1级环境管理物质

To ensure the best usage, please operate it based on the working height.  
Based on the engineering drawings, shall not exceed the maximum allowed compression.

Approve Sign

Note:

Materials:

.Plunger: Brass 20u" Au over Ni

.Barrel: Brass 20u" Au over Ni

.Spring: SUS Au

Mechanical:

.Contact force: 82g±20g at 2.5mm working stroke

.Life test: 100,000 cycles

Electrical:

.Rated current & voltage: DC 12V; 7A Max.

.Contact resistance: 50 milliohm Max.

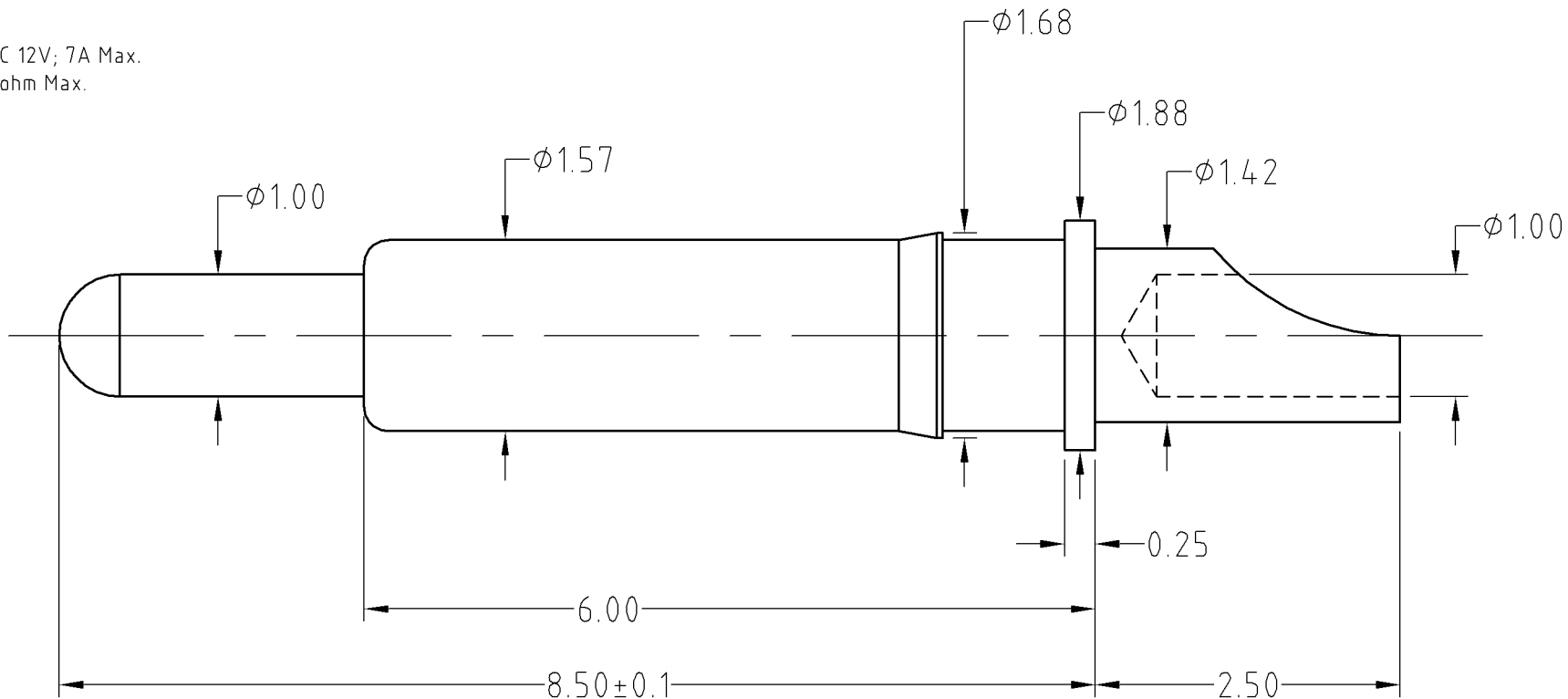

SCALE	10:1	UNIT:mm	THIS DOCUMENT IS THE SOLE PROPERTY OF CFE CORPORATION CO.,LTD., AND SHOULD NOT BE USED IN WHOLE OR IN PART WITHOUT PRIOR WRITTEN PERMISSION.	
ANGEL	±1°	A4	SHEET: 1 of 1	
0~6	±0.05			
6~30	±0.10	DRAW	PART NO.	BE117XX
30~120	±0.15	CHECK	FILE NAME	BE11711
GENERAL TOLERANCE UNLESS OTHERWISE NOTED	APPRO		TITLE.	Pogo pin connector



ECN(DCN) NO.	REV	DATE	DESCRIPTION	CHANGE	APPRO
	D0	2012.03.06	NEW		