

1

2

3

4

HSF 禁止使用1级环境管理物质

To ensure the best usage, please operate it based on the working height.
Based on the engineering drawings, shall not exceed the maximum allowed compression.

Approve Sign

Note:

Materials:

.Plunger: Brass 10u" Au over 50u" Ni

.Barrel: Brass 10u" Au over 50u" Ni

.Spring: SUS

Mechanical:

.Contact force: 34g±10g at 1.0mm working stroke

.Life test: 20,000 cycles

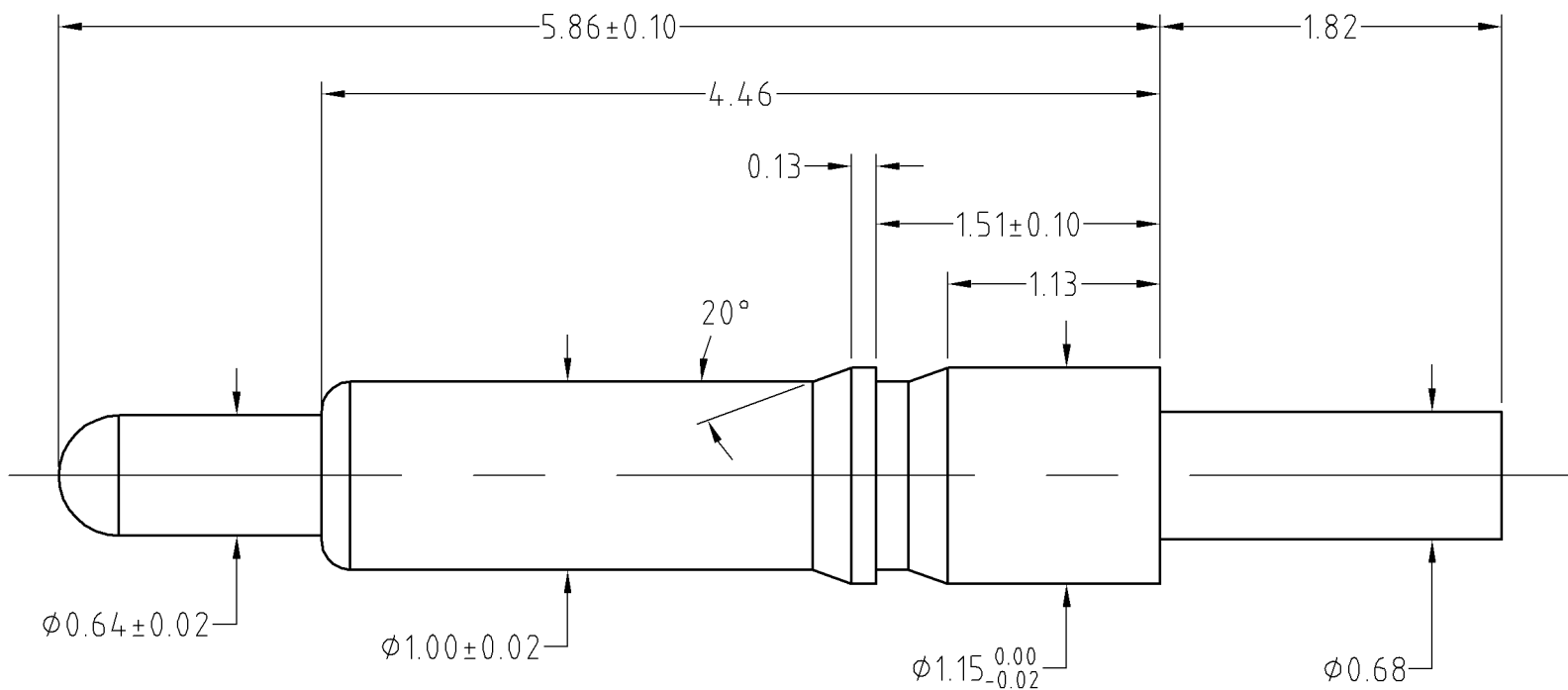

SCALE	10:1	UNIT:mm	THIS DOCUMENT IS THE SOLE PROPERTY OF CFE CORPORATION CO.,LTD., AND SHOULD NOT BE USED IN WHOLE OR IN PART WITHOUT PRIOR WRITTEN PERMISSION.	
ANGEL	$\pm 1^\circ$	A4	SHEET: 1 of 1	
0.000	± 0.02		PART NO. BP00911	
0.00	± 0.05	DRAW	FILE NAME BP00911	
0.0	± 0.10	CHECK	TITLE. Pogo pin connector	
GENERAL TOLERANCE UNLESS OTHERWISE NOTED		APPRO		

CFE 东莞市川富电子有限公司
CFE CORPORATION CO.,LTD.

ECN(DCN) NO.	REV	DATE	DESCRIPTION	CHANGE	APPRO
	D0	2013.07.06	NEW		