

HSF 禁止使用1級環境管理物質

Approve Sign

Note:

Materials:

.Plunger: Brass 15u" Au over 50u" Ni

.Barrel: Brass 3u" Au over 50u" Ni

.Spring: SUS

Mechanical:

.Contact force: 2N±20% at working height

.Life test: 20,000 cycles

Electrical:

.Rated current & voltage: DC 12V; 100mA

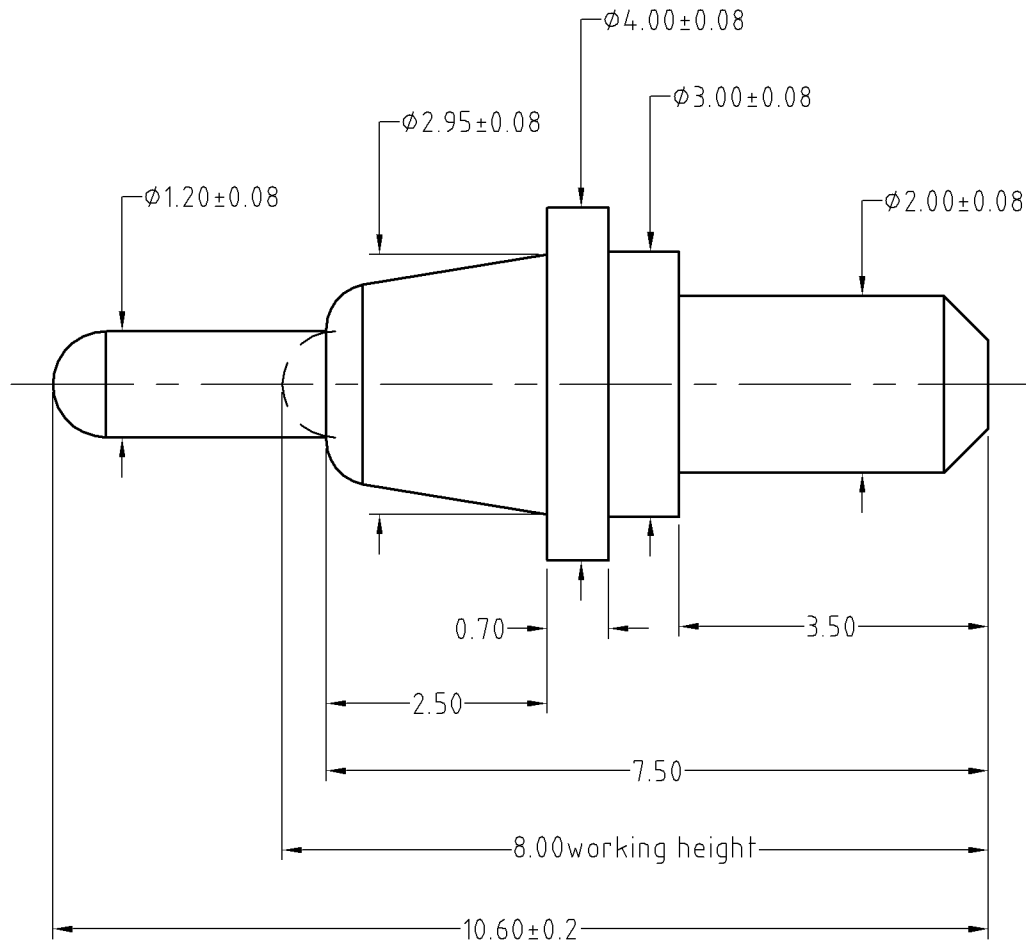

SCALE	10:1	UNIT:mm	THIS DOCUMENT IS THE SOLE PROPERTY OF CFE CORPORATION CO.,LTD., AND SHOULD NOT BE USED IN WHOLE OR IN PART WITHOUT PRIOR WRITTEN PERMISSION.	SHEET: 1 of 1	PART NO.	BP01512
ANGEL	±1°	A4				
0.000	±0.02					
0.00	±0.05	DRAW				
0.0	±0.10	CHECK				
GENERAL TOLERANCE UNLESS OTHERWISE NOTED	APPRO				TITLE.	Pogo pin connector



ECN(DCN) NO.	REV	DATE	DESCRIPTION	CHANGE	APPRO
	D0	2012.08.23	NEW		