

1

2

3

4

Note:
 Materials:
 .Plunger: Brass 0.5um Au over Ni
 .Barrel: Brass 0.5um Au over Ni
 .Spring: SUS surface treatment
 Mechanical:
 .Contact force: 120g±20% at 12.02 working height
 .Life test: 100,000 cycles (working height)
 Electrical:
 .Rated current & voltage: DC 12V; 5A
 .Contact resistance: 50 milliohm Max.

To ensure the best usage, please operate it based on the working height.
 Based on the engineering drawings, shall not exceed the maximum allowed compression.



Approve Sign

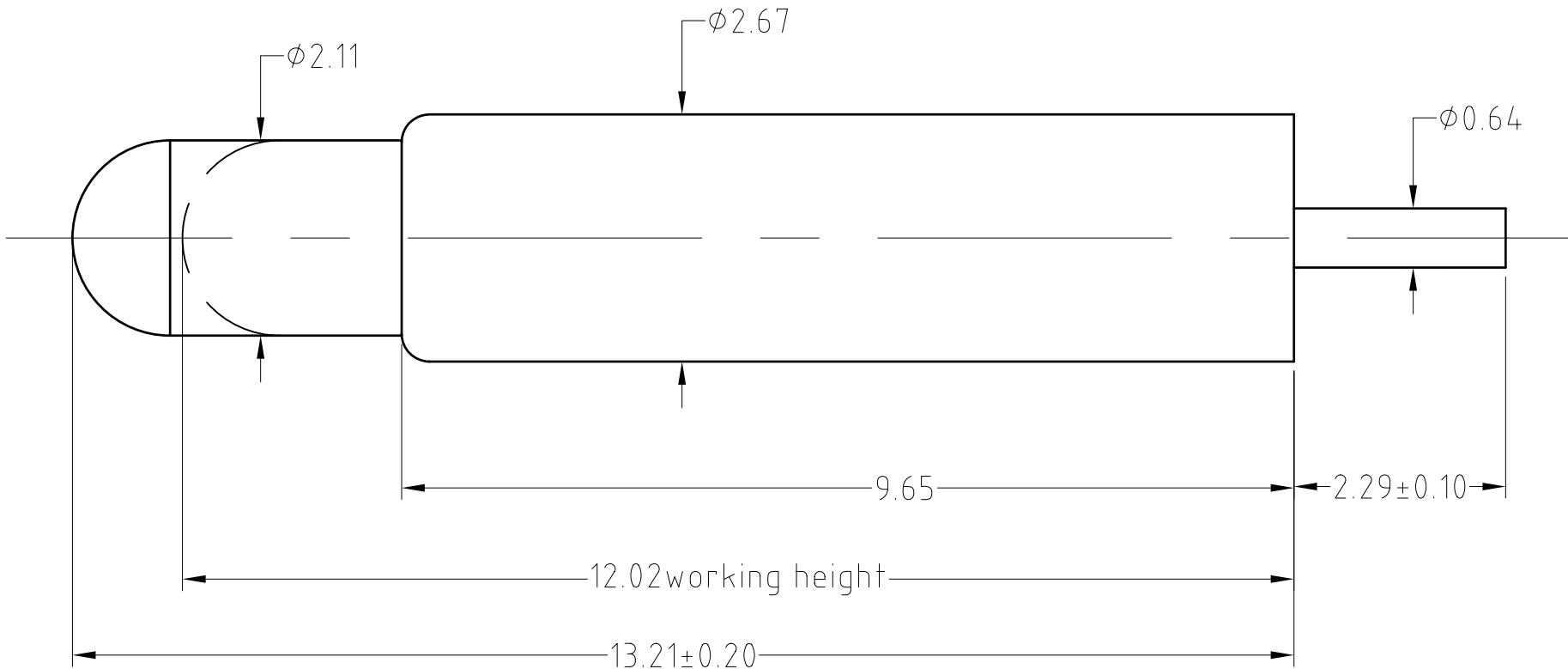

Part	NO.	Qty
Barrel	B029-B1020	1
Plunger	B029-P1020	1
Spring	B029-S01	1

SCALE	10:1	UNIT:mm	THIS DOCUMENT IS THE SOLE PROPERTY OF CFE CORPORATION CO.,LTD., AND SHOULD NOT BE USED IN WHOLE OR IN PART WITHOUT PRIOR WRITTEN PERMISSION.
ANGEL	±2°	A4	
0~6	±0.05		
6~30	±0.10	DRAW	
30~150	±0.15	CHECK	
GENERAL TOLERANCE UNLESS OTHERWISE NOTED		APPRO	

CFE 川富科技股份有限公司
 CFE CORPORATION CO.,LTD.

PART NO. BP02912

FILE NAME BP02911

TITLE. Pogo pin

ECN(DCN) NO.	D0	2013.05.30	NEW
REV	DATE	DESCRIPTION	