

Note:

1. Mechanical demands

- 1. Contact force: 120g ± 20% at working height
- 2. Plating plunger: 1u" Au over 50~100u" Ni.
- Plating barrel: 1u" Au over 50~100u" Ni.

2. Inspection

- 1. Rated current & voltage: DC12V; 1A
- 2. Life test: 10,000 cycles
- 3. Contact resistance: 50 mohm Max. at working height

3. To ensure the best usage, please operate it based on the working height.

Based on the engineering drawing, shall not exceed the maximum allowed compression.

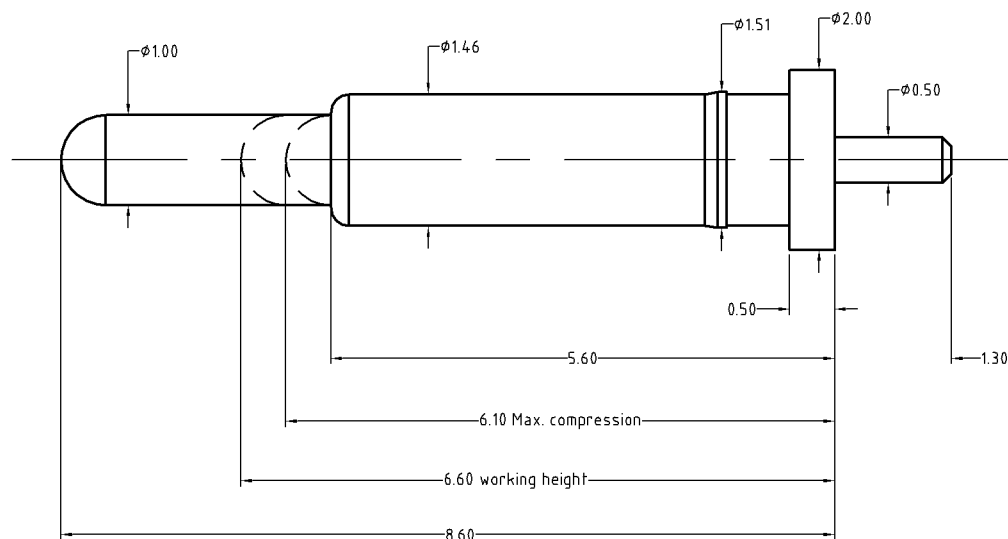

				Angle		±1°	MAT,L							
				0.0000		±0.01	COLOR							
				0.000		±0.02	DRAW	Simon	2012.08.28	TITLE.	Pogo Pin Au 1u"			
				0.00		±0.05	DESIGN			PART NO.	BP03711			
				0.0		±0.10	CHECK			FILE NAME	BP03711			
ECN(DCN) NO.	REV	DATE	DESCRIPTION	CHANGE	APPRO	GENERAL TOLERANCE UNLESS OTHERWISE NOTED	APPRO			SCALE	1:1	UNIT:mm	A4	SHEET: 1 of 1