

1

2

3

4

Note:

Materials:

.Plunger: BeCu 0.5um Au over Ni

.Barrel: Brass 0.5um Au over Ni

.Spring: SUS 0.025um Au

.Bead: insulative bead

To ensure the best usage, please operate it based on the working height.

Based on the engineering drawings, shall not exceed the maximum allowed compression.

BOM		
Part	NO.	Qty
Barrel	B060-B1020	1
Plunger	B060-P2020	1
Spring	B060-S3001	1
Bead	B060-T1000	1

A Mechanical:

.Contact force: 100g±20% at 1.5mm working stroke

.Full stroke: 2.5mm

.Life test: 50,000 cycles

Electrical:

.Rated current &amp; voltage: DC 12V; 3A Max.

.Contact resistance: 50 milliohm Max.

Operating temperature rang: -30°C~65°C

Salt Spray test: 96 hours

Side force: 1.5kg Min.

Must pass the vibration test.

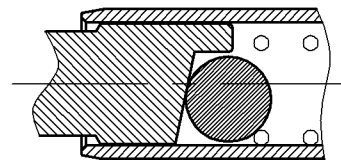

B

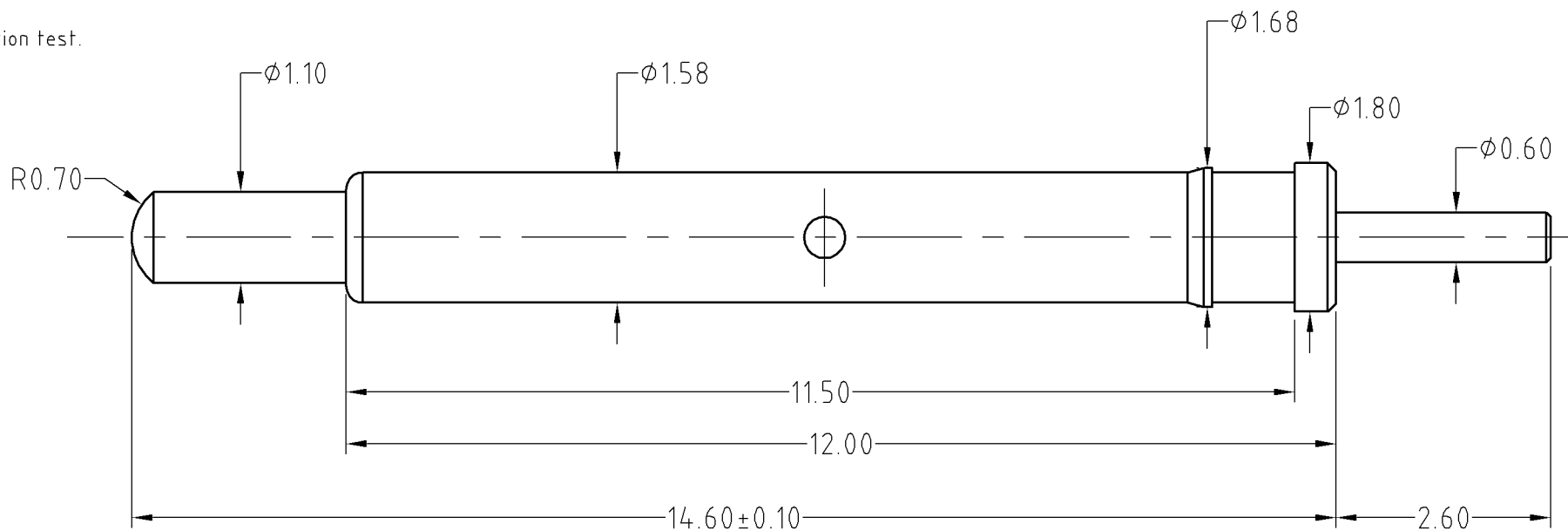

C

D

ECN(DCN) NO.	REV	DATE	DESCRIPTION
	D0	2015.04.14	NEW

SCALE	10:1	UNIT:mm	THIS DOCUMENT IS THE SOLE PROPERTY OF CFE CORPORATION CO.,LTD., AND SHOULD NOT BE USED IN WHOLE OR IN PART WITHOUT PRIOR WRITTEN PERMISSION.	
ANGEL	±1°	A4	SHEET: 1 of 1	
0~6	±0.05		PART NO.	BP06022
6~30	±0.10	DRAW	FILE NAME	BP06011
30~150	±0.15	CHECK	TITLE	Pogo pin connector
GENERAL TOLERANCE UNLESS OTHERWISE NOTED		APPRO		

**CFE** 东莞市川富电子有限公司  
CFE CORPORATION CO.,LTD.