

1

2

3

4

IISF 禁止使用1级环境管理物质

Note:

1.Mechanical demands

1.Contact force: 120g±20% at 1.0mm working stroke

2.Full stroke: 1.70mm

3.Plating plunger: Brass 3u" Au over 50~100u" Ni.

Plating barrel: Brass 3u" Au over 50~100u" Ni.

2.Inspection(working stroke)

1.Rated current & voltage: DC12V; 1A

2.Life test: 20,000 cycles

3.Contact resistance: 50 mohm Max.

Approve Sign

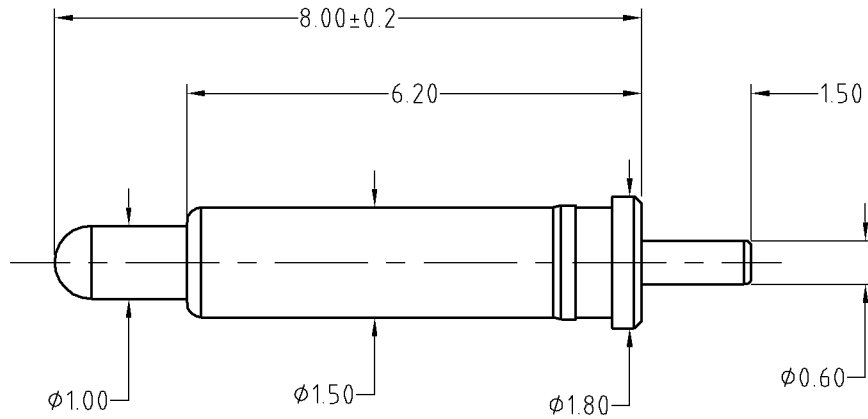

SCALE	10:1	UNIT:mm	THIS DOCUMENT IS THE SOLE PROPERTY OF CFC CORPORATION CO.,LTD., AND SHOULD NOT BE USED IN WHOLE OR IN PART WITHOUT PRIOR WRITTEN PERMISSION.
ANGEL	±1°	A4	
0.000	±0.02		
0.00	±0.05	DRAW	
0.0	±0.10	CHECK	SHEET: 1 of 1

ECN/DCN NO.	REV	DATE	DESCRIPTION	CHANGE	APPRO	GENERAL TOLERANCE UNLESS OTHERWISE NOTED	APPRO	PART NO.	BP06411
		2012.08.23	NEW					FILE NAME	BP06411
								TITLE	Paga pin connector