

Approve Sign

Note:

1.Mechanical demands

- 1.Contact force: 120g±20% at working height
- 2.Plating plunger: Brass 3u" Au over 50~100u" Ni.
- Plating barrel: Brass 3u" Au over 50~100u" Ni.

2.Inspection(working height)

- 1.Rated current & voltage: DC12V; 1A
- 2.Life test: 10,000 cycles
- 3.Contact resistance: 50 mohm Max.

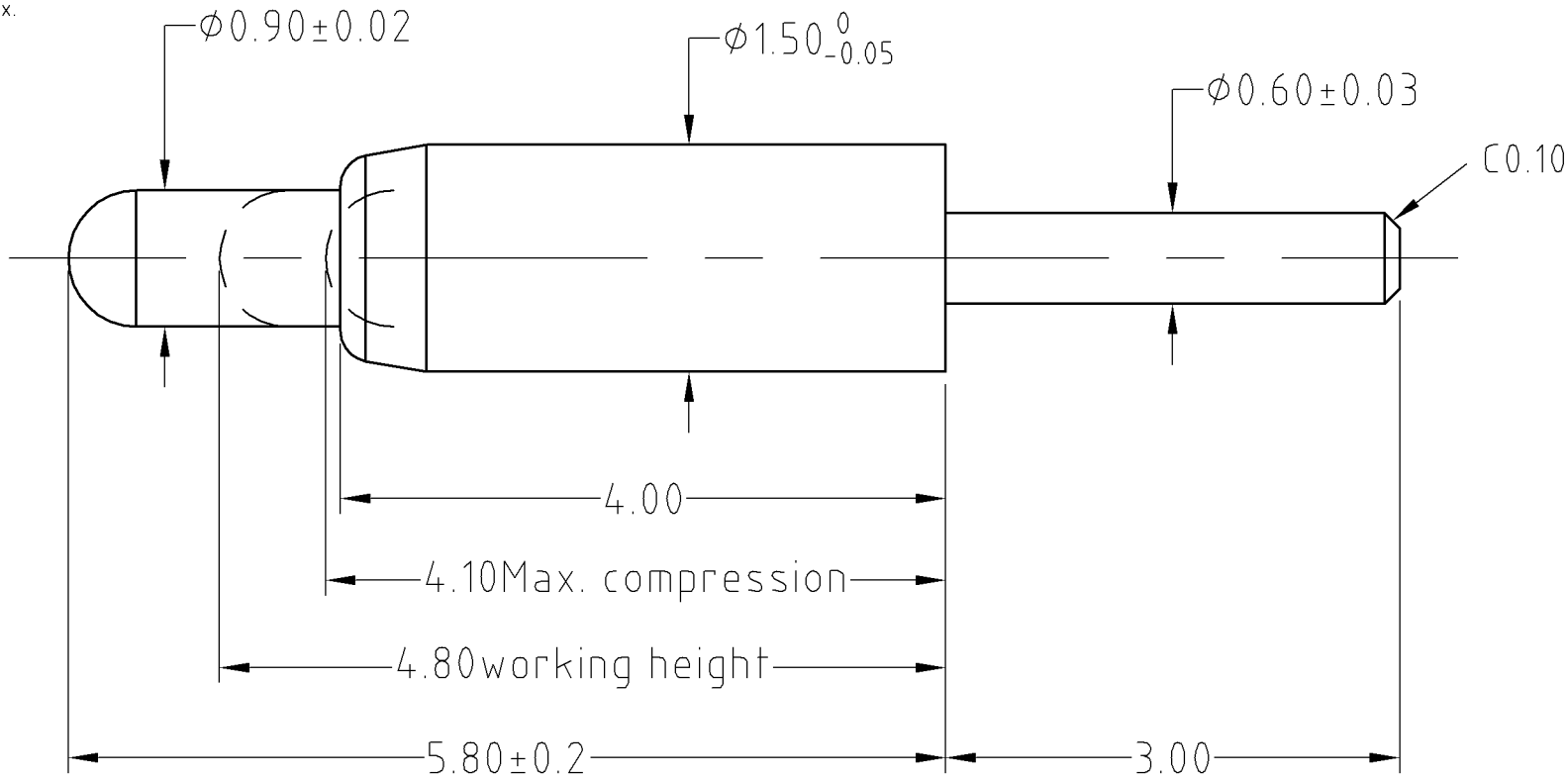

Angle	±1°	MAT'L																	
0.0000	±0.01	COLOR						TITLE.	Pogo pin										
0.000	±0.02	DRAW						PART NO.	BP07111										
0.00	±0.05	DESIGN						FILE NAME	BP07111										
0.0	±0.10	CHECK						SCALE	1:1	UNIT:mm	A4		SHEET: 1 of 1						
GENERAL TOLERANCE UNLESS OTHERWISE NOTED																			

	D0	2012.08.23	NEW																
ECN(DCN) NO.	REV	DATE	DESCRIPTION		CHANGE	APPRO													