

1

2

3

4

Note:

Materials:

.Plunger: Brass 10u" Au over Ni

.Barrel: Brass 5u" Au over Ni

.Spring: SUS

Mechanical:

.Contact force: 120g±20% at 1.5mm working stroke

.Max. stroke: 2.2mm

.Life test: 20,000 cycles

Electrical:

.Rated current & voltage: DC 12V; 1A

.Contact resistance: 50 milliohm Max.

To ensure the best usage, please operate it based on the working height.
Based on the engineering drawings, shall not exceed the maximum allowed compression.



Approve Sign

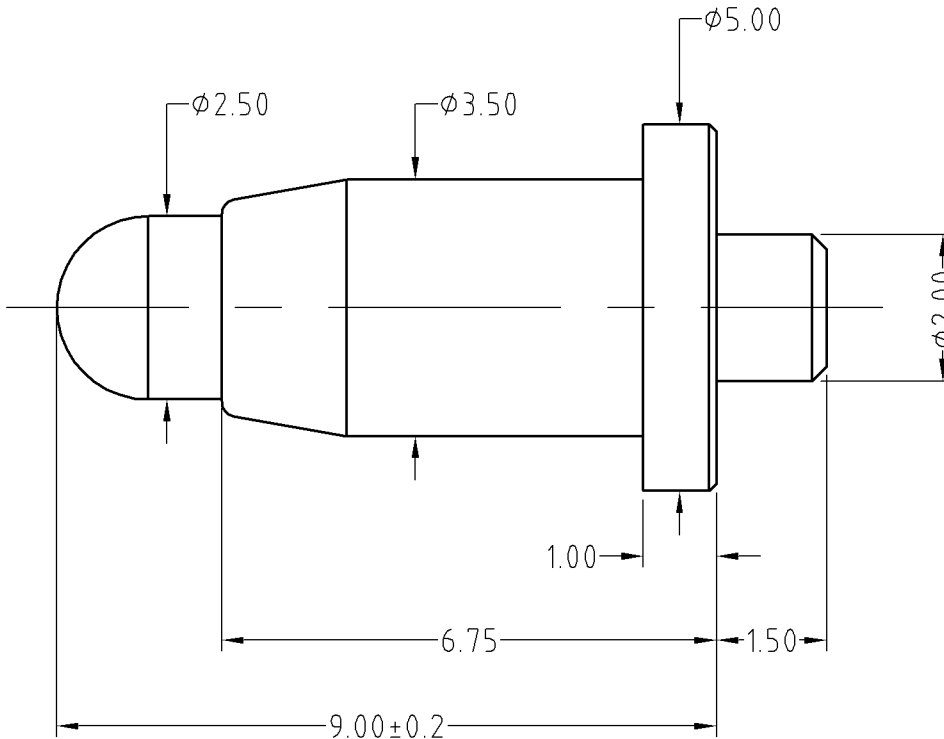

SCALE	10:1	UNIT:mm	THIS DOCUMENT IS THE SOLE PROPERTY OF CFE CORPORATION CO.,LTD., AND SHOULD NOT BE USED IN WHOLE OR IN PART WITHOUT PRIOR WRITTEN PERMISSION.	
ANGEL	±1°	A4	SHEET: 1 of 1	
0~6	±0.05		PART NO. BP07811	
6~30	±0.10	DRAW	FILE NAME BP07811	
30~150	±0.15	CHECK	TITLE. Pogo pin connector	
GENERAL TOLERANCE UNLESS OTHERWISE NOTED		APPRO		



_____	A0	2014.03.08	NEW
ECN(DCN) NO.	REV	DATE	DESCRIPTION