

HSF 禁止使用1级环境管理物质

Note:

1.Mechanical demands

- 1.Contact force: 85g±20% at working height
- 2.Plating plunger: BrassC3604 30u" Au over 50u" Ni.
- Plating barrel: BrassC3604 10u" Au over 50u" Ni.
- Plating spring: SUS 1u" Au
- Bead: Ceramic bead

2.Inspection(working height)

- 1.Rated current & voltage: DC12V; 4.5A Max.
- 2.Life test: 40,000 cycles
- 3.Contact resistance: 50 mohm Max.

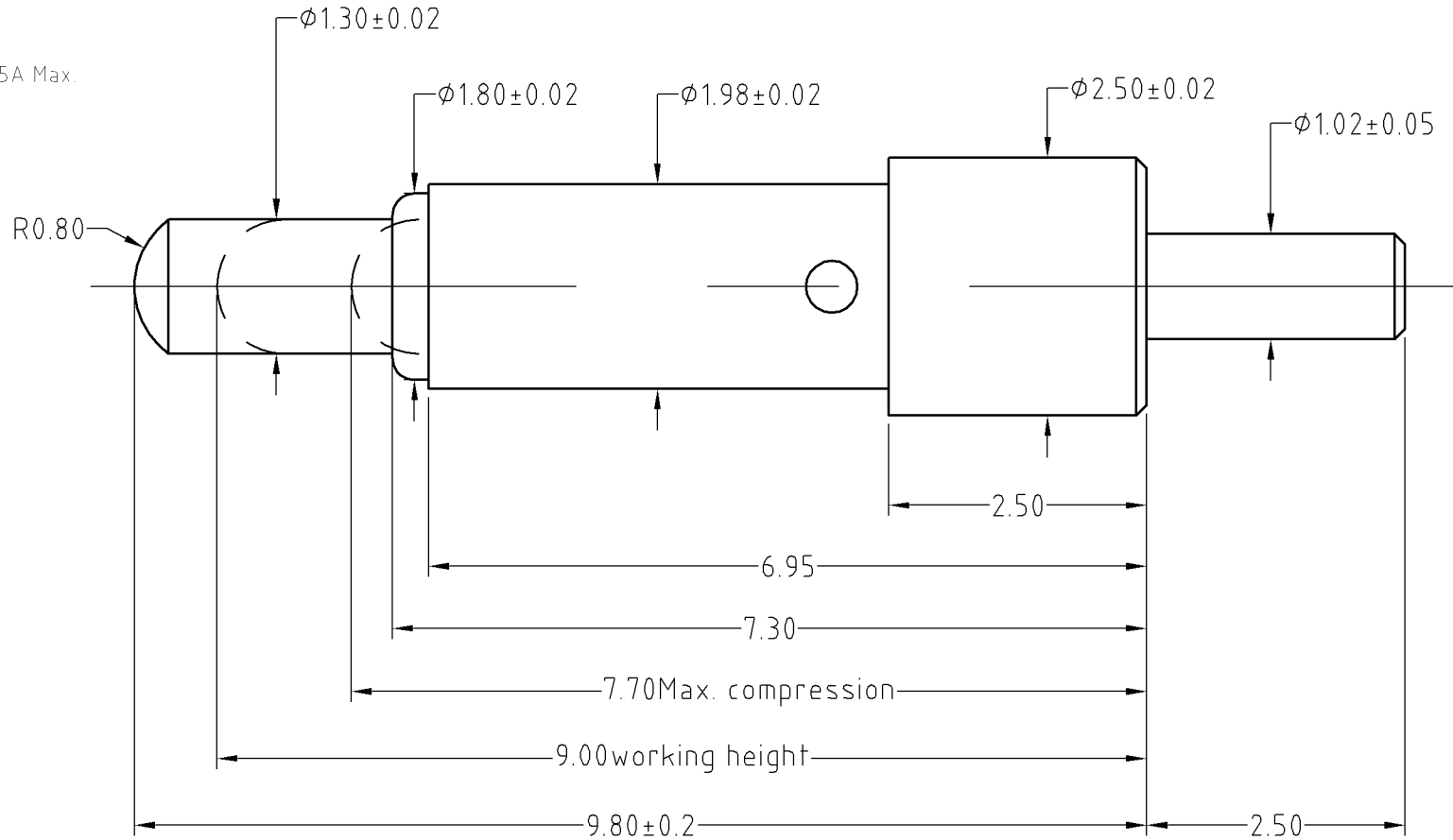

SCALE	10:1	UNIT:mm	THIS DOCUMENT IS THE SOLE PROPERTY OF CFE CORPORATION CO.,LTD., AND SHOULD NOT BE USED IN WHOLE OR IN PART WITHOUT PRIOR WRITTEN PERMISSION.	
ANGEL	$\pm 1^\circ$	A4	SHEET: 1 of 1	
	± 0.02			
	± 0.05	DRAW		PART NO. BP08611
	± 0.10	CHECK		FILE NAME BP08611
GENERAL TOLERANCE UNLESS OTHERWISE NOTED		APPRO		TITLE Pogo pin connector

ECN(DCN) NO.	REV	DATE	DESCRIPTION	CHANGE	APPRO
	D0	2012.08.23	NEW		