

HSF 禁止使用1级环境管理物质

Note:

1.Mechanical demands

- .Contact force: 110g±20% at working height
- .Plating plunger: Brass 10u" Au over 50u" Ni.
- .Plating barrel: Brass 10u" Au over 50u" Ni.
- .Plating spring: SUS304 1u" Au

2.Inspection(working stroke)

- .Rated current & voltage: DC12V; 1A
- .Life test: 20,000 cycles
- .Contact resistance: 50 mohm Max.

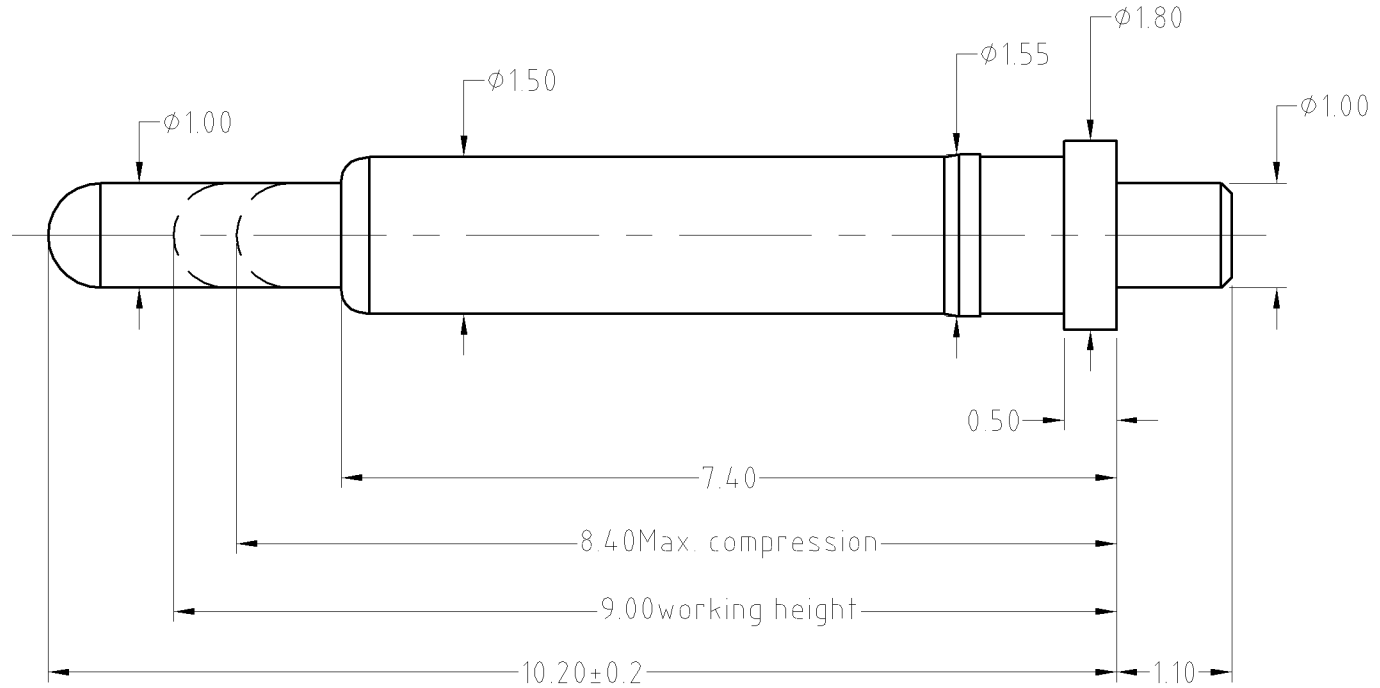

SCALE	10:1	UNIT:mm	THIS DOCUMENT IS THE SOLE PROPERTY OF CFE CORPORATION CO.,LTD., AND SHOULD NOT BE USED IN WHOLE OR IN PART WITHOUT PRIOR WRITTEN PERMISSION.						
ANGEL	±1°	A4	SHEET: 1 of 1						
0.000	±0.02								
0.00	±0.05	DRAW		PART NO. v					
0.0	±0.10	CHECK		FILE NAME BP0891					
ECN(DCN) NO.	REV	DATE	DESCRIPTION	CHANGE	APPRO	GENERAL TOLERANCE UNLESS OTHERWISE NOTED	APPRO	TITLE	Pogo pin connector