

HSF 禁止使用1级环境管理物质

Approve Sign

Note:

- 1.Mechanical demands
 - .Contact force: 100g±20% at 1.0mm working stroke
 - .Plating plunger: Brass 15u" Au over 50u" Ni.
 - .Plating barrel: Brass 15u" Au over 50u" Ni.
- 2.Inspection(working stroke)
 - .Rated current & voltage: DC12V; 1A
 - .Life test: 20,000 cycles
 - .Contact resistance: 50 mohm Max.

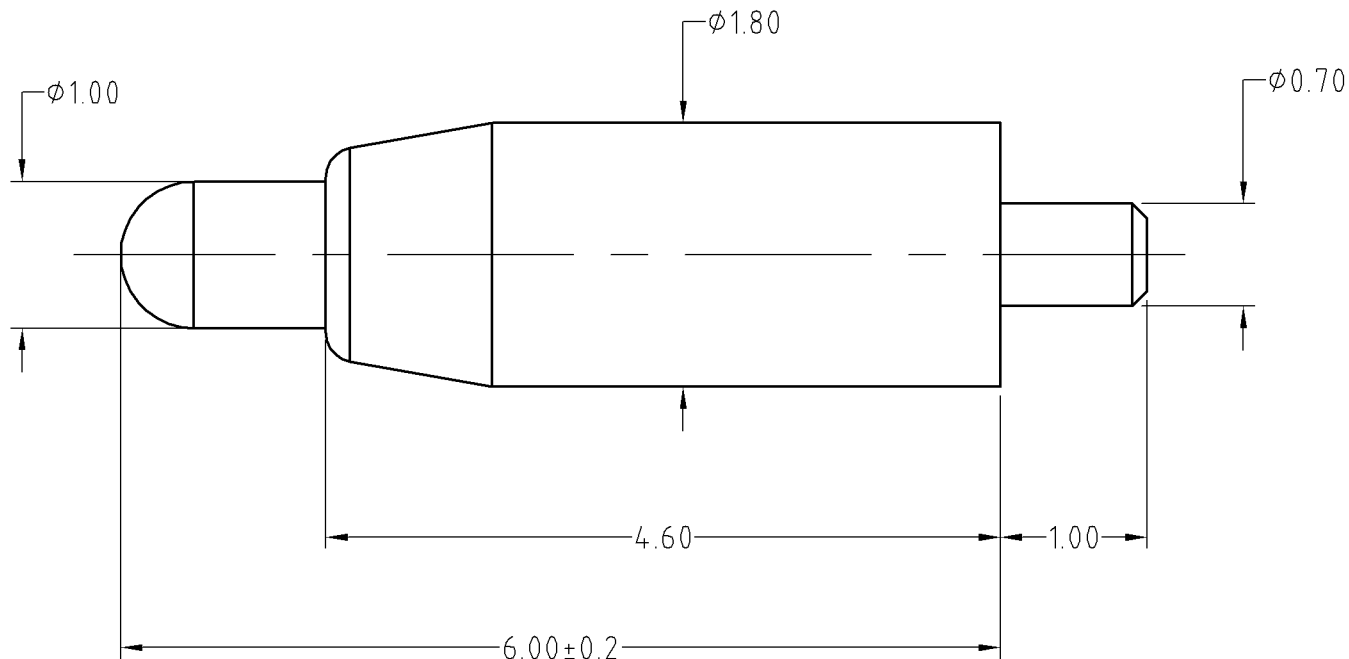

SCALE	10:1	UNIT:mm	THIS DOCUMENT IS THE SOLE PROPERTY OF CFE CORPORATION CO.,LTD., AND SHOULD NOT BE USED IN WHOLE OR IN PART WITHOUT PRIOR WRITTEN PERMISSION.	
ANGEL	$\pm 1^\circ$	A4	SHEET: 1 of 1	
0.000	± 0.02			
0.00	± 0.05	DRAW	PART NO.	BP09211
0.0	± 0.10	CHECK	FILE NAME	BP09211
GENERAL TOLERANCE UNLESS OTHERWISE NOTED	APPRO	TITLE.	Pago pin connector	



ECN(DCN) NO.	REV	DATE	DESCRIPTION	CHANGE	APPRO
	D0	2013.05.30	NEW		