

HSF 禁止使用1级环境管理物质

Approve Sign

Note:

Materials:

- .Plunger: Brass 20u" Au over 50u" Ni
- .Barrel & Plug: Brass 10u" Au over 50u" Ni
- .Spring: SUS

Mechanical:

- .Contact force: 100g±20% at 5.0mm working height
- .Life test: 20,000 cycles

Electrical(working height):

- .Rated current & voltage: DC12V; 1A
- .Contact resistance: 50 milliohm Max.

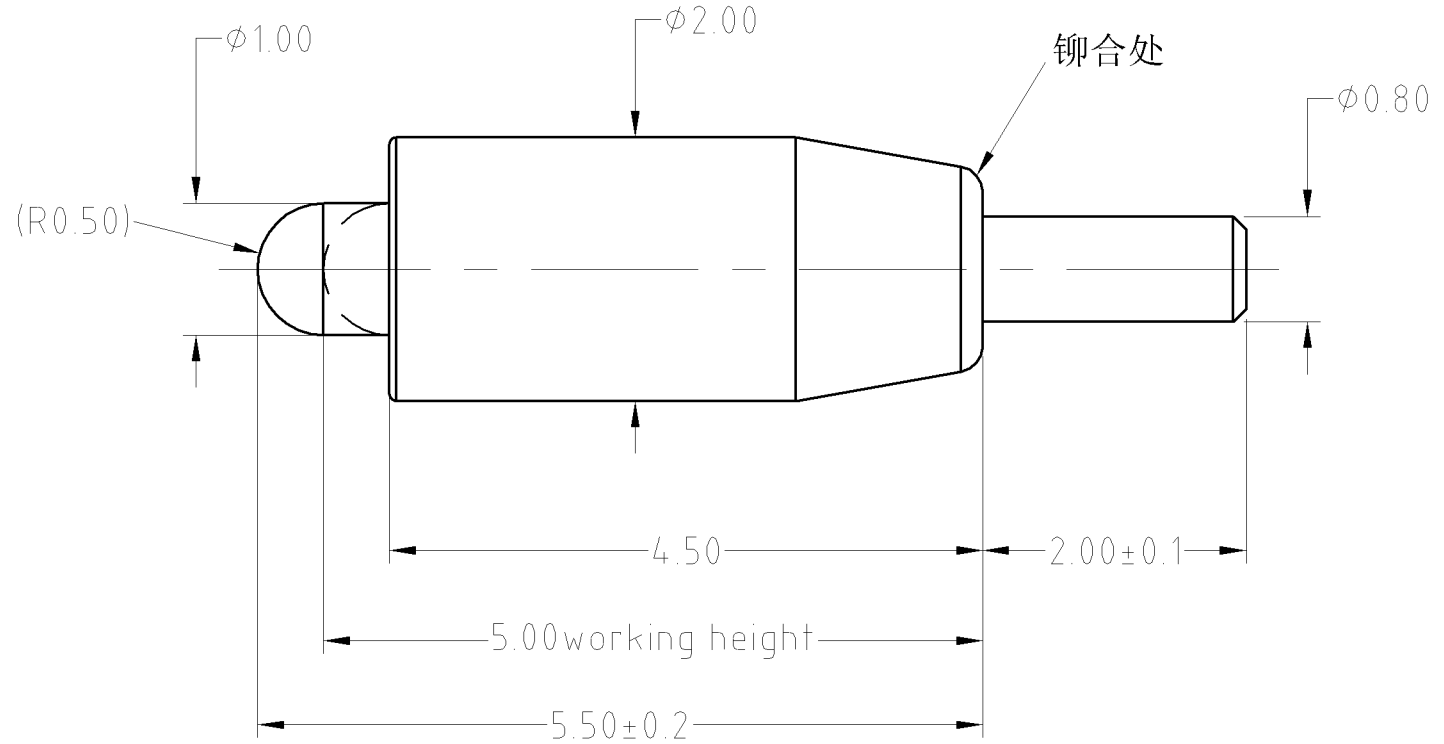

SCALE	10:1	UNIT:mm	THIS DOCUMENT IS THE SOLE PROPERTY OF CFE CORPORATION CO.,LTD., AND SHOULD NOT BE USED IN WHOLE OR IN PART WITHOUT PRIOR WRITTEN PERMISSION.	
ANGEL	±1°	A4	SHEET: 1 of 1	
0.000	±0.02		PART NO. BP09911	
0.00	±0.05	DRAW	FILE NAME BP09911	
0.0	±0.10	CHECK	TITLE. Pogo pin connector	
GENERAL TOLERANCE UNLESS OTHERWISE NOTED		APPRO		



ECN(DCN) NO.	REV	DATE	DESCRIPTION	CHANGE	APPRO
	A0	2013.07.31	NEW		