

HSF 禁止使用1级环境管理物质

To ensure the best usage, please operate it based on the working height.  
Based on the engineering drawings, shall not exceed the maximum allowed compression.

Note:

Materials:

.Insulator: Black high temperature plastics UL94 V-0

.Plunger: Brass 15u" Au over Ni

.Barrel: Brass 5u" Au over Ni

.Spring: SUS

Mechanical:

.Contact force: 120g±20% at working stroke

.Life test: 20,000 cycles

Electrical:

.Rated current & voltage: DC 12V; 1A

.Contact resistance: 50 milliohm Max.

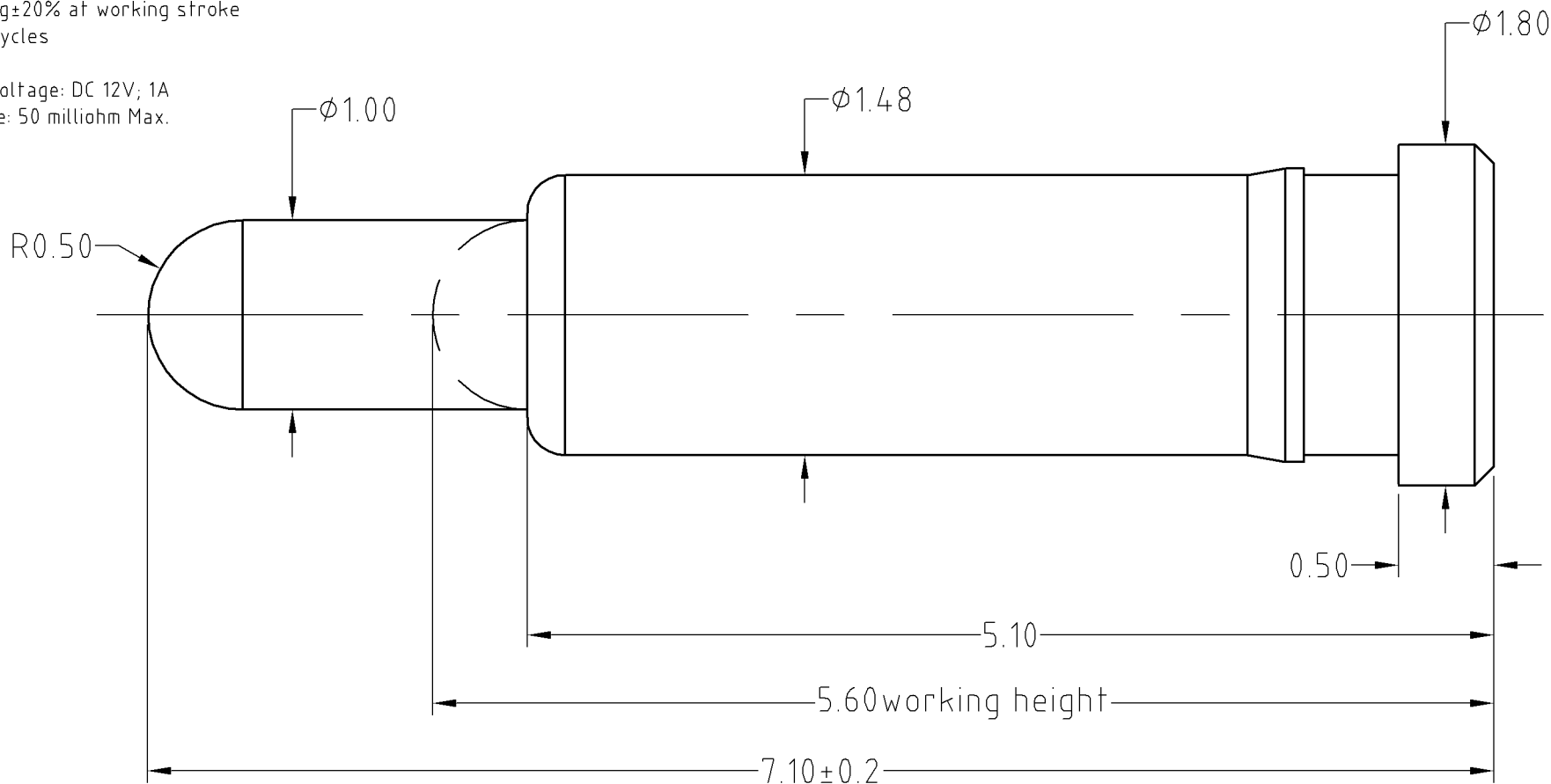

SCALE	10:1	UNIT:mm	THIS DOCUMENT IS THE SOLE PROPERTY OF CFE CORPORATION CO.,LTD., AND SHOULD NOT BE USED IN WHOLE OR IN PART WITHOUT PRIOR WRITTEN PERMISSION.	SHEET: 1 of 1
ANGEL	$\pm 1^\circ$	A4		
0.000	$\pm 0.02$			
0.00	$\pm 0.05$	DRAW		
0.0	$\pm 0.10$	CHECK		
GENERAL TOLERANCE UNLESS OTHERWISE NOTED			APPRO	
PART NO.		BP10811		
FILE NAME		BP0XX11		
TITLE.		Pogo pin connector		

**CFE** 东莞市川富电子有限公司  
CFE CORPORATION CO.,LTD.

ECN(DCN) NO.	REV	DATE	DESCRIPTION	CHANGE	APPRO
	D0	2013.07.06	NEW		