

1

2

3

4

Note:

Materials:

.Plunger & Plug: Brass Au over Ni

.Barrel: Brass Au over Ni

.Spring: SUS

Mechanical:

.Contact force: 50g±20g at 0.7mm working stroke

.Life test: 100,000 cycles

Electrical:

.Rated current & voltage: DC 12V; 1A Max.

.Contact resistance: 50 milliohm Max.

To ensure the best usage, please operate it based on the working height.  
Based on the engineering drawings, shall not exceed the maximum allowed compression.



Approve Sign

BP118 GG	
GG-Plating:	
Barrel	Plunger
1-0.125um	1-0.125um
2-0.25um	2-0.25um
4-0.5um	4-0.5um
...	...

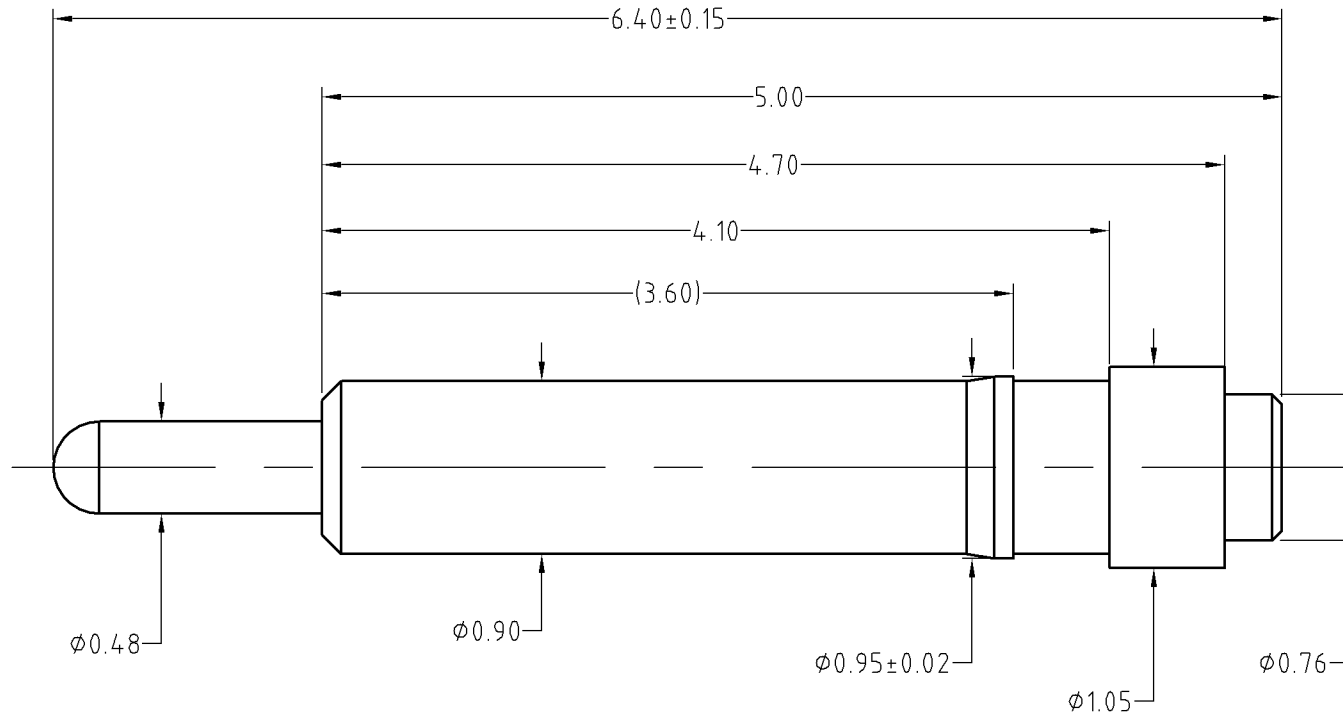

SCALE	10:1	UNIT:mm	THIS DOCUMENT IS THE SOLE PROPERTY OF CFE CORPORATION CO.,LTD., AND SHOULD NOT BE USED IN WHOLE OR IN PART WITHOUT PRIOR WRITTEN PERMISSION.	<b>CFE</b> 东莞市川富电子有限公司 CFE CORPORATION CO.,LTD.
ANGEL	±1°	A4		
0-6	±0.05		SHEET: 1 of 1	
6-30	±0.10	DRAW		PART NO. BP118GG
30-150	±0.15	CHECK		FILE NAME BP118XX
GENERAL TOLERANCE UNLESS OTHERWISE NOTED		APPRO		TITLE. Pogo pin connector

	D0	2013.05.30	NEW
ECN(DCN) NO.	REV	DATE	DESCRIPTION