

1

2

3

4

Note:

Materials:

.Plunger: Brass 0.25um Au over Ni

.Barrel: Brass 0.5um Au over Ni

.Spring: SUS

Mechanical:

.Contact force: 100g±20% at 10.90mm working height

.Life test: 50,000 cycles

Electrical:

.Rated current & voltage: DC 12V; 3A Max.



.Contact resistance: 50 milliohm Max.

To ensure the best usage, please operate it based on the working height.
Based on the engineering drawings, shall not exceed the maximum allowed compression.

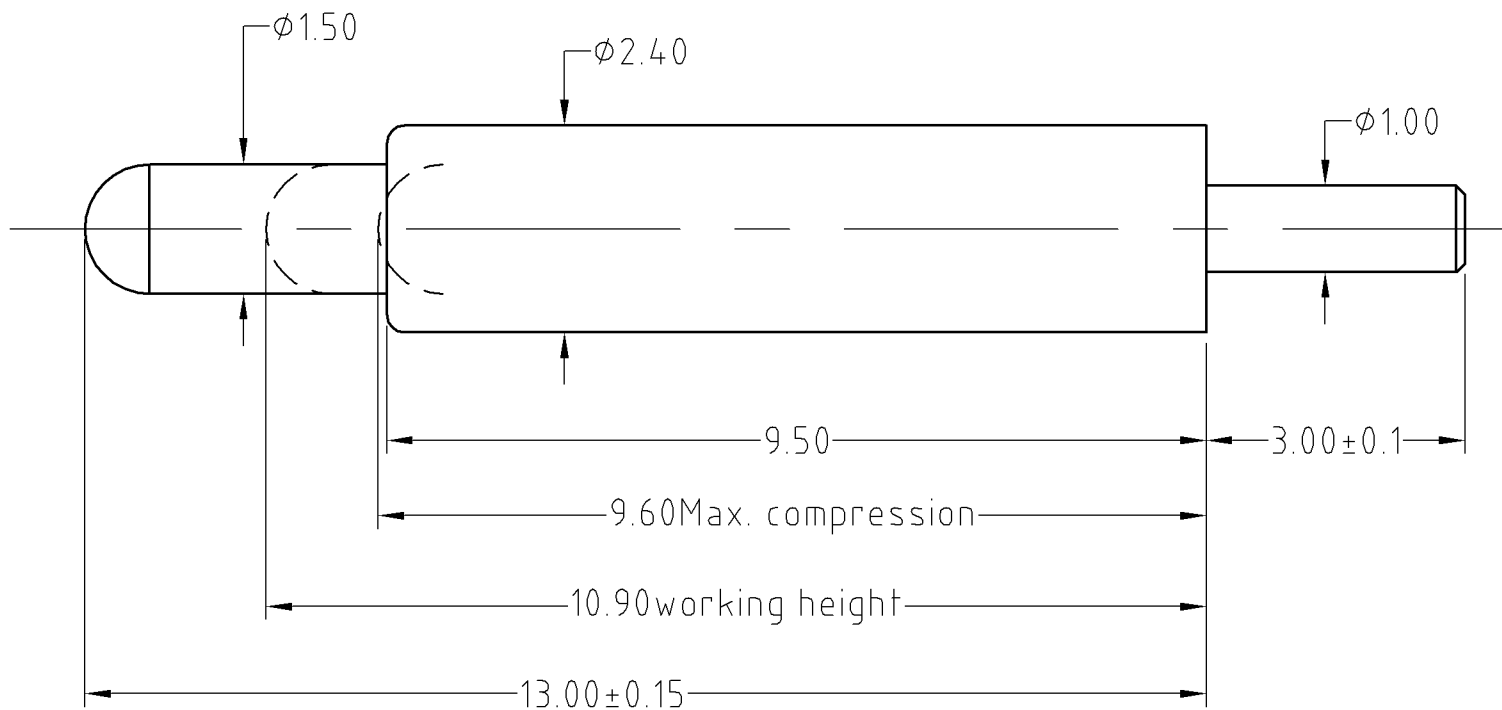

Approve Sign



SCALE	10:1	UNIT:mm	THIS DOCUMENT IS THE SOLE PROPERTY OF CFE CORPORATION CO.,LTD., AND SHOULD NOT BE USED IN WHOLE OR IN PART WITHOUT PRIOR WRITTEN PERMISSION.		 东莞市川富电子有限公司 CFE CORPORATION CO.,LTD.	
ANGEL	$\pm 1^\circ$	A4	SHEET: 1 of 1			
0~6	± 0.05				PART NO.	BP13506
6~30	± 0.10	DRAW			FILE NAME	BP135XX
30~150	± 0.15	CHECK			TITLE.	Pogo pin connector
GENERAL TOLERANCE UNLESS OTHERWISE NOTED		APPRO				

_____	A0	2013.12.20	NEW
ECN(DCN) NO.	REV	DATE	DESCRIPTION