

1

2

3

4

Note:

Materials:

.Plunger: Brass 10u" Au over Ni

.Barrel: Brass 10u" Au over Ni

.Spring: SUS surface treatment

Mechanical:

.Contact force: 500g±20% at 12.95mm working height

.Life test: 20,000 cycles

Electrical:

.Rated current & voltage: DC 12V; 2A

.Contact resistance: 50 milliohm Max.

To ensure the best usage, please operate it based on the working height.
Based on the engineering drawings, shall not exceed the maximum allowed compression.



Approve Sign

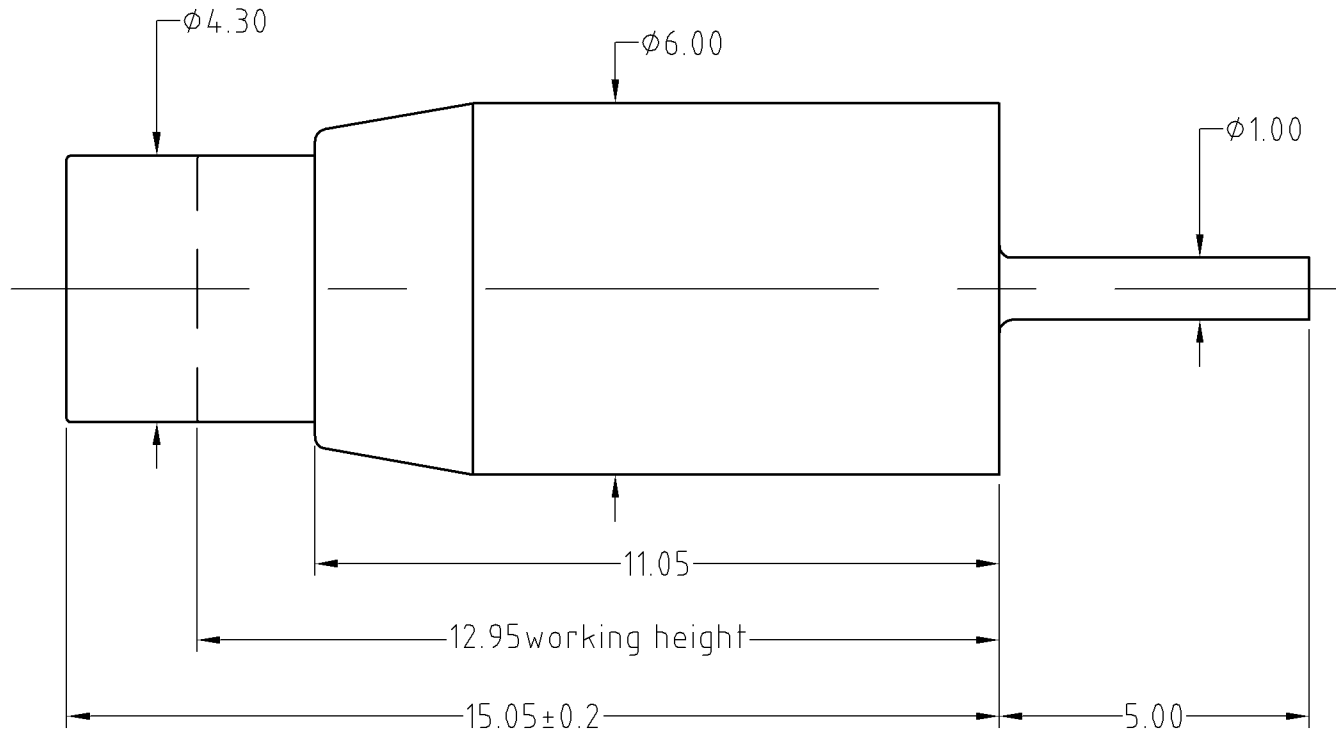

A

B

C

D

	D0	2013.05.30	NEW
ECN(DCN) NO.	REV	DATE	DESCRIPTION

SCALE	10:1	UNIT:mm	THIS DOCUMENT IS THE SOLE PROPERTY OF CFE CORPORATION CO.,LTD., AND SHOULD NOT BE USED IN WHOLE OR IN PART WITHOUT PRIOR WRITTEN PERMISSION.	
ANGEL	$\pm 1^\circ$	A4	SHEET: 1 of 1	
0-6	± 0.05		PART NO.	BP17311
6-30	± 0.10	DRAW	FILE NAME	BP173XX
30-150	± 0.15	CHECK	TITLE.	Pogo pin connector
GENERAL TOLERANCE UNLESS OTHERWISE NOTED		APPRO		

