

1

2

3

4

Note:

Materials:

.Plunger: Brass 16u" Au over Ni

.Barrel: Brass 4u" Au over Ni

.Spring: SUS 304

Mechanical:

.Contact force: 60g±10g at 1.70mm working height

.Life test: 10,000 cycles

Electrical:

.Rated current & voltage: DC 5V; 1A

.Contact resistance: 100 milliohm Max.

To ensure the best usage, please operate it based on the working height.

Based on the engineering drawings, shall not exceed the maximum allowed compression.



Approve Sign

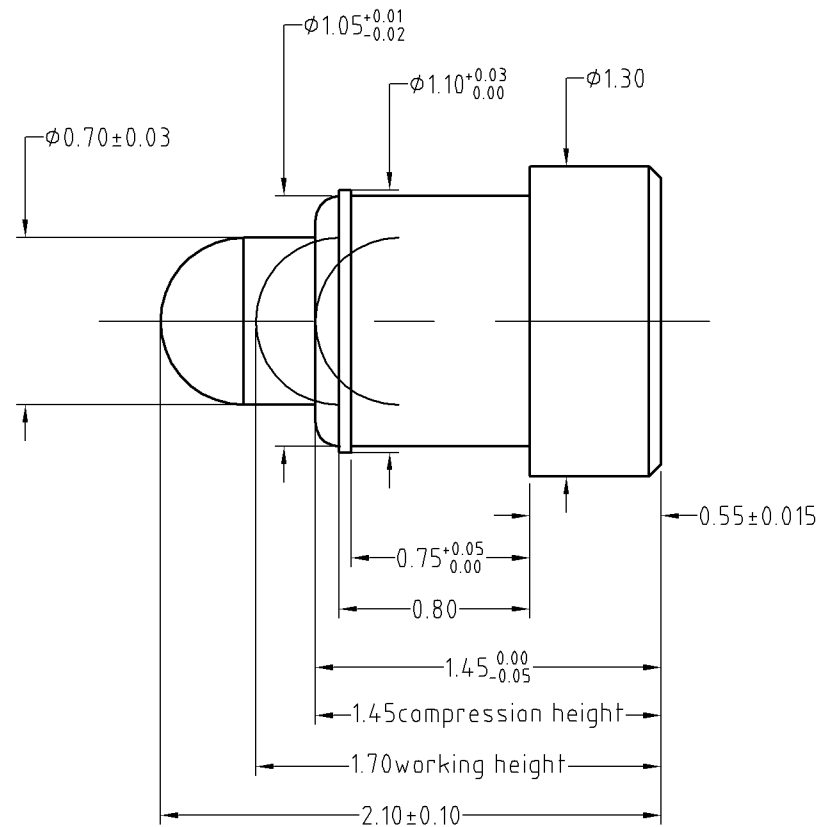
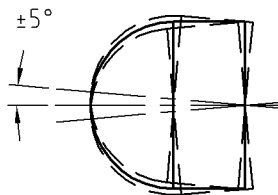

SCALE	10:1	UNIT:mm	THIS DOCUMENT IS THE SOLE PROPERTY OF CFE CORPORATION CO.,LTD., AND SHOULD NOT BE USED IN WHOLE OR IN PART WITHOUT PRIOR WRITTEN PERMISSION.	
ANGEL	±1°	A4	SHEET: 1 of 1	
0~6	±0.05		PART NO.	BP18311
6~30	±0.10	DRAW	FILE NAME	BP183XX
30~150	±0.15	CHECK	TITLE.	Pogo pin connector
GENERAL TOLERANCE UNLESS OTHERWISE NOTED		APPRO		



	D0	2013.05.30	NEW
ECN(DCN) NO.	REV	DATE	DESCRIPTION