

1

2

3

4

Note:

Materials:

.Plunger: Brass 0.25um Au over Ni

.Barrel: Brass 0.125um Au over Ni

.Spring: SUS surface treatment

Mechanical:

.Contact force: 110g±20% at 4.70mm working height

.Life test: 20,000 cycles

Electrical:

.Rated current & voltage: DC 12V; 1A Max.

.Contact resistance: 50 milliohm Max.

To ensure the best usage, please operate it based on the working height.

Based on the engineering drawings, shall not exceed the maximum allowed compression.



Approve Sign

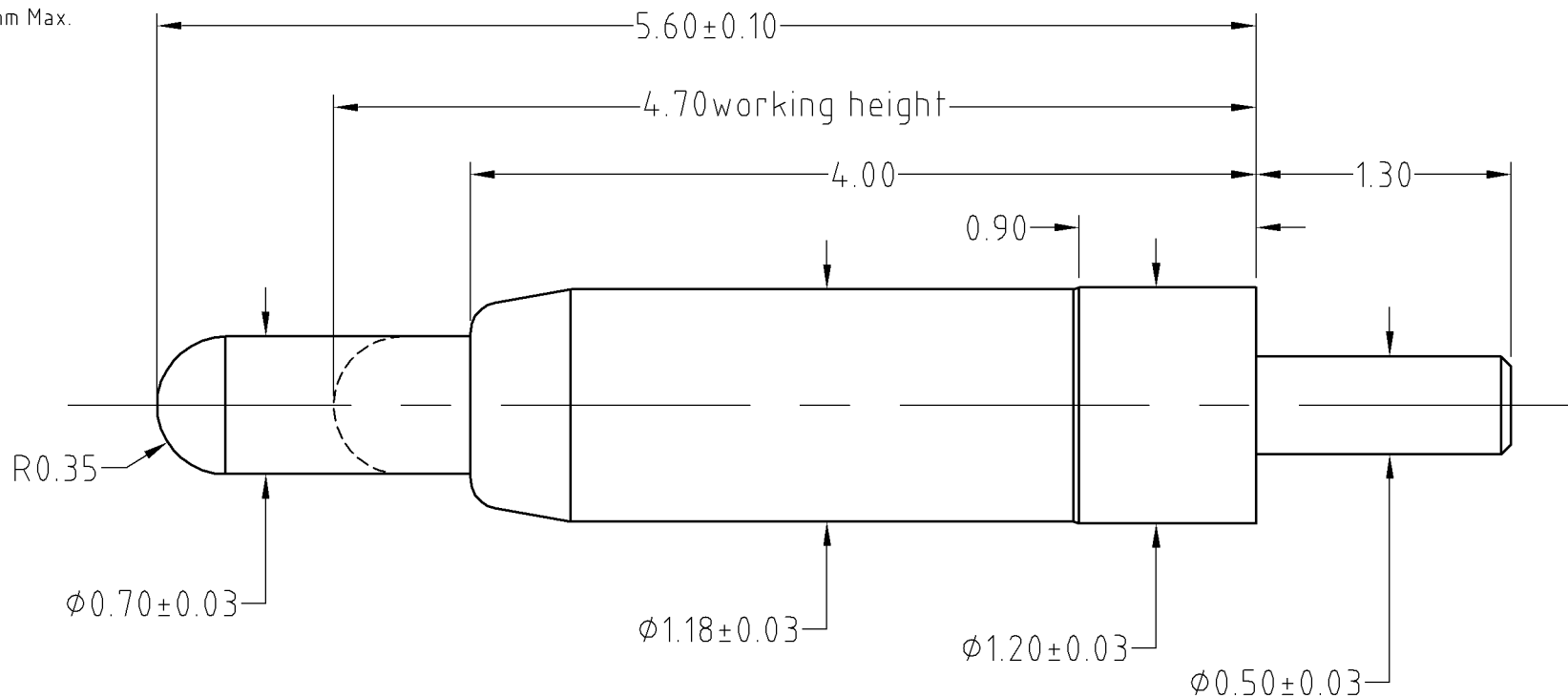

SCALE	10:1	UNIT:mm	THIS DOCUMENT IS THE SOLE PROPERTY OF CFE CORPORATION CO.,LTD., AND SHOULD NOT BE USED IN WHOLE OR IN PART WITHOUT PRIOR WRITTEN PERMISSION.	
ANGEL	$\pm 1^\circ$	A4	SHEET: 1 of 1	
0~6	± 0.05		PART NO.	BP25212
6~30	± 0.10	DRAW	FILE NAME	BP252XX
30~150	± 0.15	CHECK	TITLE.	Pogo pin connector
GENERAL TOLERANCE UNLESS OTHERWISE NOTED		APPRO		

CFE 东莞市川富电子有限公司
CFE CORPORATION CO.,LTD.

	D0	2014.08.15	NEW
ECN(DCN) NO.	REV	DATE	DESCRIPTION