

Note:

Materials:

.Insulator: Black high temperature plastics UI94 V-0

.Plunger: Brass 0.125um Au over Ni.

.Spring: SUS surface treatment

.Barrel: Brass 0.125um Au over Ni.

A Mechanical:

.Contact force: 70g±20g at 1.0mm working stroke

.Full stroke: 1.4mm

.Life test: 20,000 cycles

Electrical:

.Rated current & voltage: DC12V; 3A Max.

.Contact resistance: 50 milliohm Max.

Standard tolerances are:

.Diameters: +/-0.05mm

.Lengths: +/-0.15mm

.Angles: +/-2°



Approve Sign

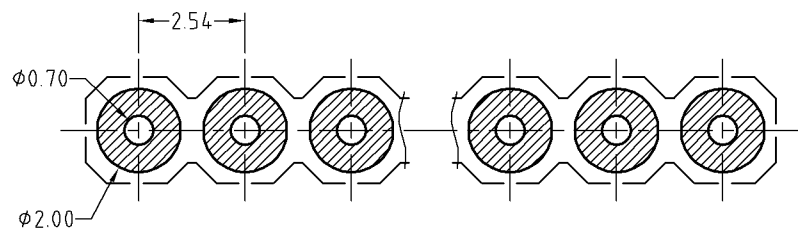
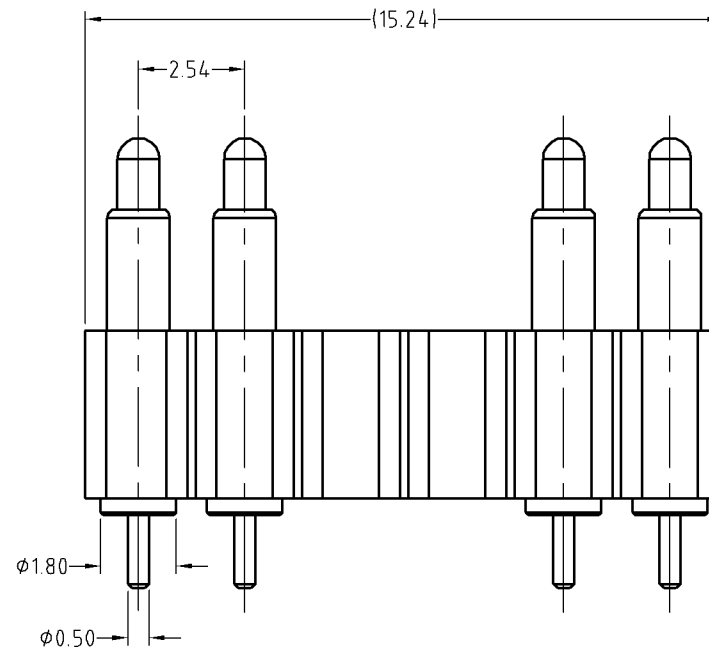
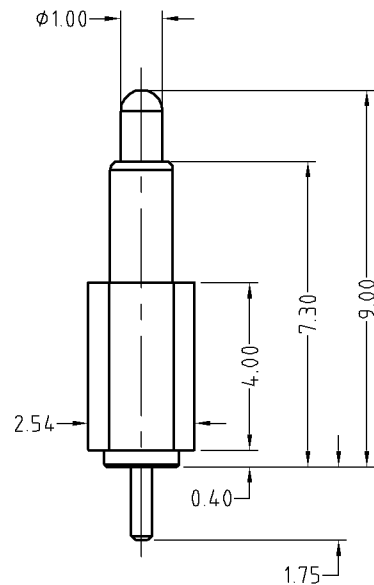

Recommended pcb layout  
Layout tolerance: ±0.05mm

SCALE	10:1	UNIT:mm	THIS DOCUMENT IS THE SOLE PROPERTY OF CFE CORPORATION CO.,LTD., AND SHOULD NOT BE USED IN WHOLE OR IN PART WITHOUT PRIOR WRITTEN PERMISSION.	 <b>CFE</b> 东莞市川富电子有限公司 CFE CORPORATION CO.,LTD.	
ANGEL	±1°	A4			
0-6	±0.05		SHEET: 1 of 1	PART NO.	BP31111-04254E0A
6-30	±0.10	DRAW		FILE NAME	BP311XX
30-150	±0.15	CHECK		TITLE	Pogo pin connector
GENERAL TOLERANCE UNLESS OTHERWISE NOTED		APPRO			

ECN(DCN) NO.	A0	2014.11.27	NEW
REV	DATE	DESCRIPTION	