

Note:

Materials:

- .Plunger: Brass 0.075um Au over Ni
- .Barrel: Brass 0.075um Au over Ni
- .Spring: SUS surface treatment

Mechanical:

- .Contact force: 120g±20% at 7.0mm working height
- .Max. compression: 6.5mm
- .Life test: 20,000 cycles

Electrical:

- .Rated current & voltage: DC 12V; 1A
- .Contact resistance: 50 milliohm Max.

To ensure the best usage, please operate it based on the working height.
Based on the engineering drawings, shall not exceed the maximum allowed compression.



Approve Sign

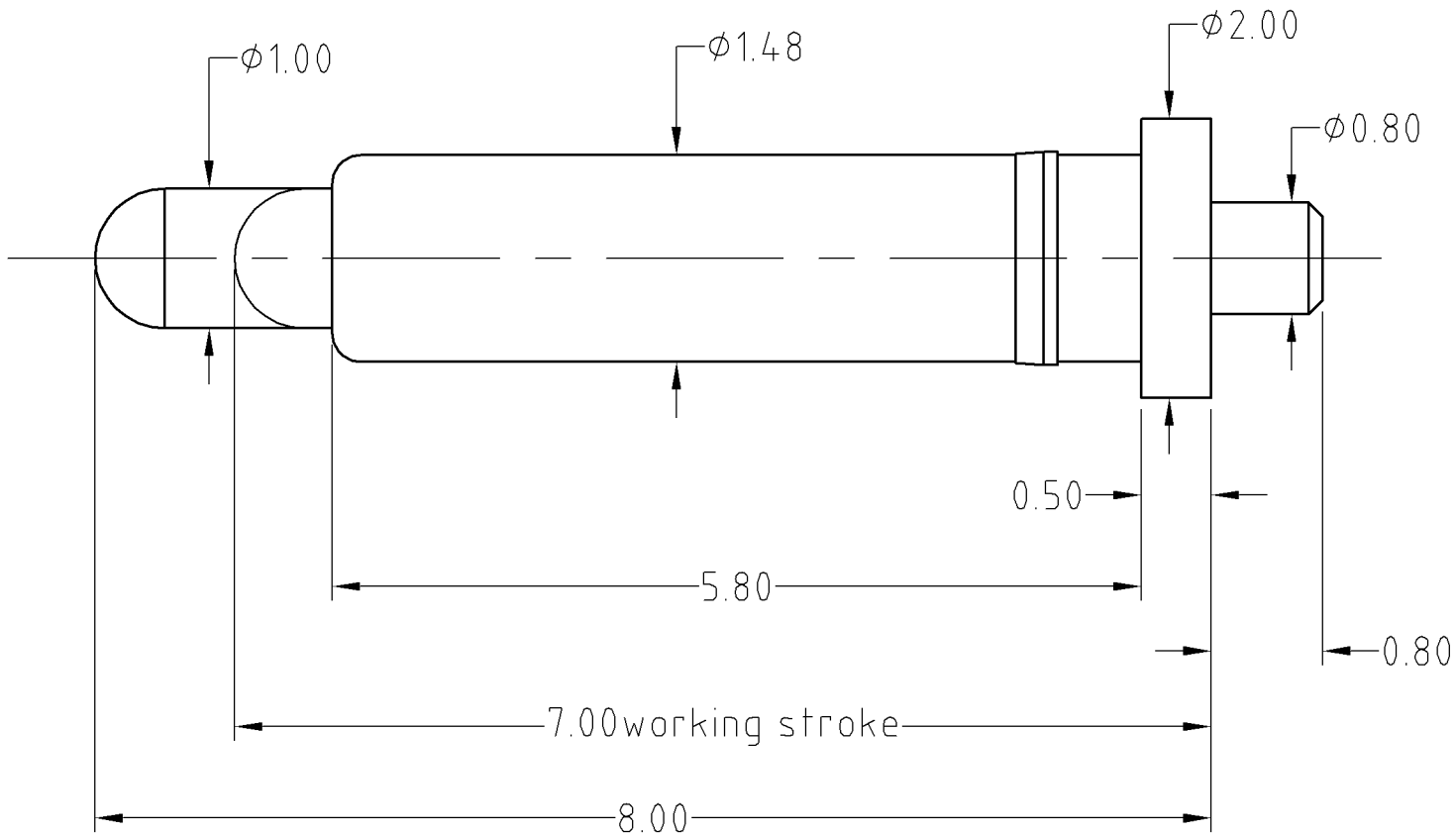

BOM		
Part	NO.	Qty
Plunger	B394-P1003	1
Barrel	M200-P2003	1
Spring	B394-S1001	1

SCALE	10:1	UNIT:mm	THIS DOCUMENT IS THE SOLE PROPERTY OF CFE CORPORATION CO.,LTD., AND SHOULD NOT BE USED IN WHOLE OR IN PART WITHOUT PRIOR WRITTEN PERMISSION.	SHEET: 1 of 1	PART NO.	BP394.11
ANGEL	±1°	A4				FILE NAME
0-6	±0.10				TITLE.	Pogo pin connector
6-30	±0.15	DRAW				
30-150	±0.20	CHECK				
GENERAL TOLERANCE UNLESS OTHERWISE NOTED		APPRO				



ECN(DCN) NO.	D0	2013.05.30	NEW
REV	DATE	DESCRIPTION	