

1

2

3

4

Note:

Materials:

.Insulator: Black high temperature plastics UL94 V-0

.Plunger: Brass 0.375um Au over Ni.

.Spring: SUS surface treatment

.Barrel: Brass 0.375um Au over Ni.

A Mechanical:

.Contact force: 40g±20g at 1.0mm working stroke

.Full stroke: 1.8mm

.Life test: 20,000 cycles

Electrical:

.Rated current & voltage: DC12V; 1A Max.

.Contact resistance: 50 milliohm Max.

To ensure the best usage, please operate it based on the working height.

Based on the engineering drawings, shall not exceed the maximum allowed compression.



Approve Sign

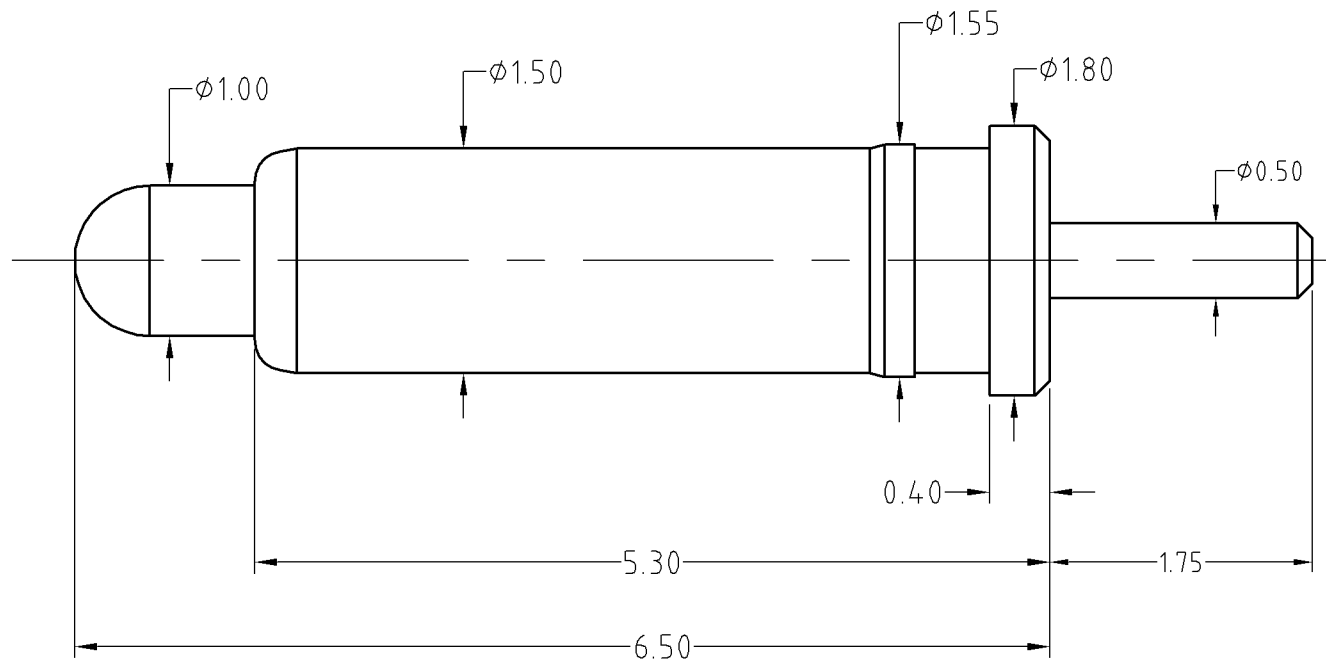

BOM

Part	NO.	Qty
Plunger	M200-P1015	1
Barrel	M310-B1015	1
Spring	B400-S1001	1

SCALE	10:1	UNIT:mm	THIS DOCUMENT IS THE SOLE PROPERTY OF CFE CORPORATION CO.,LTD., AND SHOULD NOT BE USED IN WHOLE OR IN PART WITHOUT PRIOR WRITTEN PERMISSION.	
ANGEL	$\pm 1^\circ$	A4	SHEET: 1 of 1	
0-6	± 0.10			
6-30	± 0.15	DRAW	PART NO.	BP40011
30-150	± 0.20	CHECK	FILE NAME	BP400XX
GENERAL TOLERANCE UNLESS OTHERWISE NOTED		APPRO	TITLE.	Pogo pin connector

CFE 东莞市川富电子有限公司
CFE CORPORATION CO.,LTD.

_____	D0	2013.05.30	NEW
ECN(DCN) NO.	REV	DATE	DESCRIPTION