

Note:  
 Materials:  
 .Plunger: Brass Au 0.125um over Ni  
 .Barrel: Brass Au 0.125um over Ni  
 .Spring: SUS 304 surface treatment  
 Mechanical:  
 .Contact force: 100g±20% at 0.8mm working stroke.  
 .Life test: 50,000 cycles  
 Electrical:  
 .Rated current & voltage: DC 12V; 1A  
 .Contact resistance: 50 milliohm Max.  
 Cannot be used as the charging

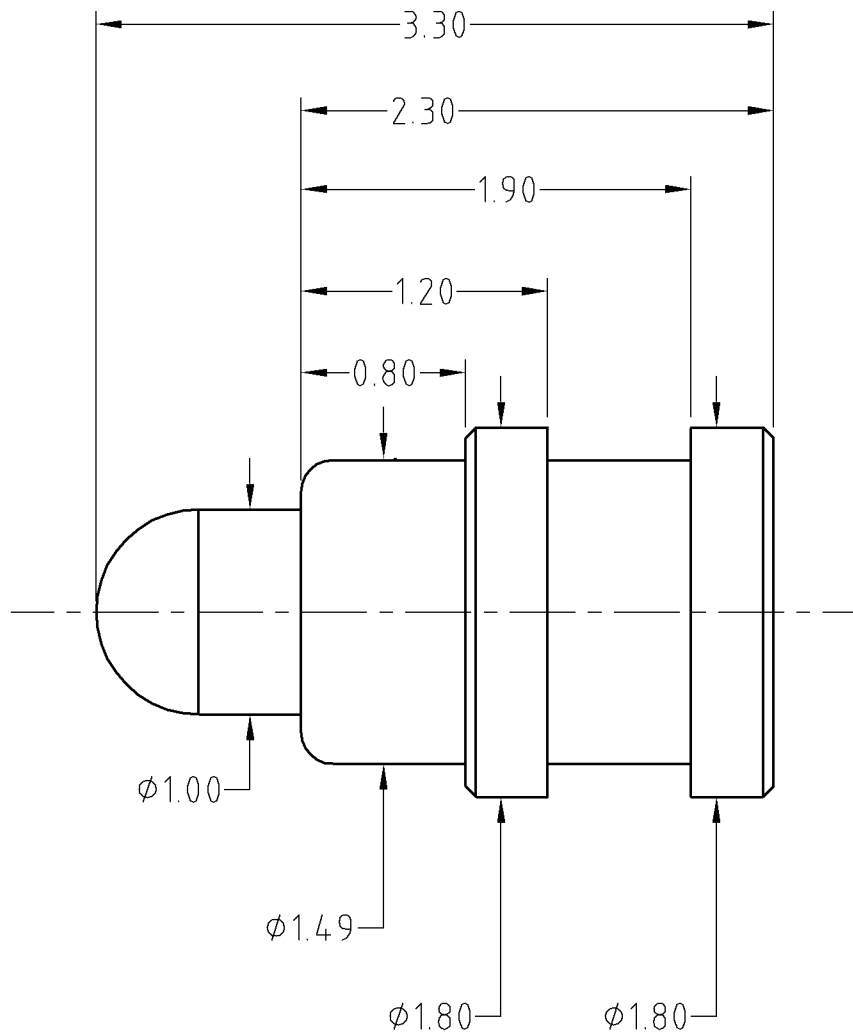

Approve Sign

BOM		
Part	NO.	Qty
Plunger	M601-P6005	1
Barrel	B463-B2005	1
Spring	M606-S1001	1

SCALE	10:1	UNIT:mm	THIS DOCUMENT IS THE SOLE PROPERTY OF CFE CORPORATION CO.,LTD., AND SHOULD NOT BE USED IN WHOLE OR IN PART WITHOUT PRIOR WRITTEN PERMISSION.	SHEET: 1 of 1
ANGEL	±1°	A4		
0-6	±0.05			
6-30	±0.10	DRAW		
30-150	±0.15	CHECK		
GENERAL TOLERANCE UNLESS OTHERWISE NOTED		APPRO		

		东莞市川富电子有限公司 CFE CORPORATION CO.,LTD.	
PART NO.	BP46321	FILE NAME	BP463XX
TITLE	Pogo pin connector		

ECN(DCN) NO.	D0	2015.07.02	NEW
REV	DATE	DESCRIPTION	