

Note:

Materials:

.Plunger: Brass 0.25um Au over Ni

.Barrel: Brass 0.25um Au over Ni

.Spring: SUS 304 Au

Mechanical:

.Contact force: 50gs20g at 0.70mm working stroke.

.Life test: 20,000 cycles

Electrical:

.Rated current & voltage: DC 12V; 1A

.Contact resistance: 50 milliohm Max.

To ensure the best usage, please operate it based on the working height.  
Based on the engineering drawings, shall not exceed the maximum allowed compression.



Approve Sign

| BOM     |            |     |
|---------|------------|-----|
| Part    | NO.        | Qty |
| Plunger | M100-P1010 | 1   |
| Barrel  | M110-B1010 | 1   |
| Spring  | B517-S1001 | 1   |

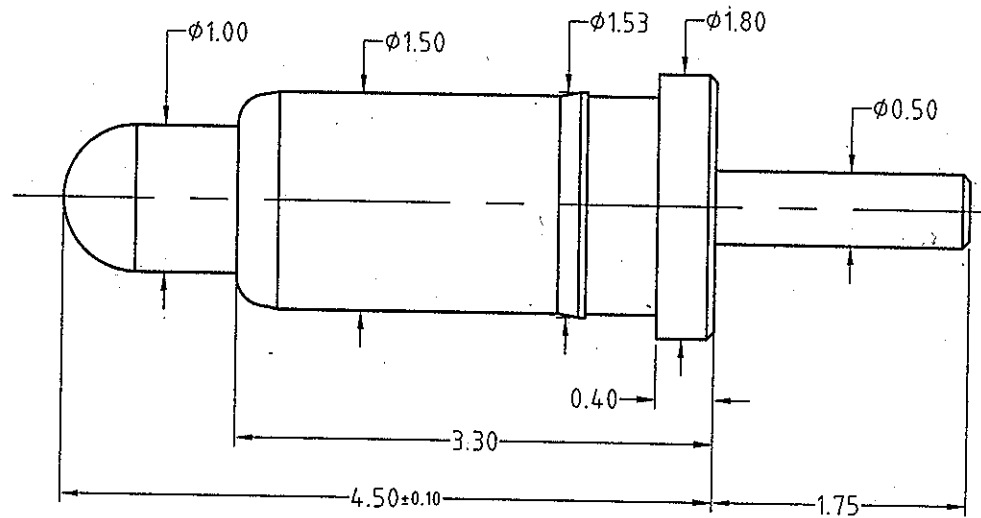

东莞市川富电子有限公司  
2016.04.13  
文件受控章

|  |       |         |  |
|--|-------|---------|--|
| SCALE                                    | 10:1  | UNIT:mm | THIS DOCUMENT IS THE SOLE PROPERTY OF CFE CORPORATION CO.,LTD., AND SHOULD NOT BE USED IN WHOLE OR IN PART WITHOUT PRIOR WRITTEN PERMISSION. |
| ANGEL                                    | ±2°   | A4      |  |
| 0-6                                      | ±0.05 |         | SHEET: 1 of 1  |
| 6-30                                     | ±0.10 | DRAW    |  |
| 30-150                                   | ±0.15 | CHECK   |  |
| GENERAL TOLERANCE UNLESS OTHERWISE NOTED |       | APPRO   |  |

**CFE** 东莞市川富电子有限公司  
CFE CORPORATION CO.,LTD.

|              |    |            |             |
|--------------|----|------------|-------------|
| ECN(DCN) NO. | A0 | 2016.04.13 | NEW         |
| REV          |    | DATE       | DESCRIPTION |

|           |          |
|-----------|----------|
| PART NO.  | BP51711  |
| FILE NAME | BP517XX  |
| TITLE.    | Pogo pin |