

Note:

Materials:

- .Plunger: Brass 0.5um Au over Ni
- .Barrel: Brass 0.5um Au over Ni
- .Spring: SUS 304 Au

Mechanical:

- .Contact force: 100gs±20% at 2.7mm working stroke
- .Max. compression: 4.7mm
- .Life test: 100,000 cycles

Electrical:

- .Rated current & voltage: DC 12V; 5A
- .Contact resistance: 15 milliohm Max.



To ensure the best usage, please operate it based on the working height.  
Based on the engineering drawings, shall not exceed the maximum allowed compression.

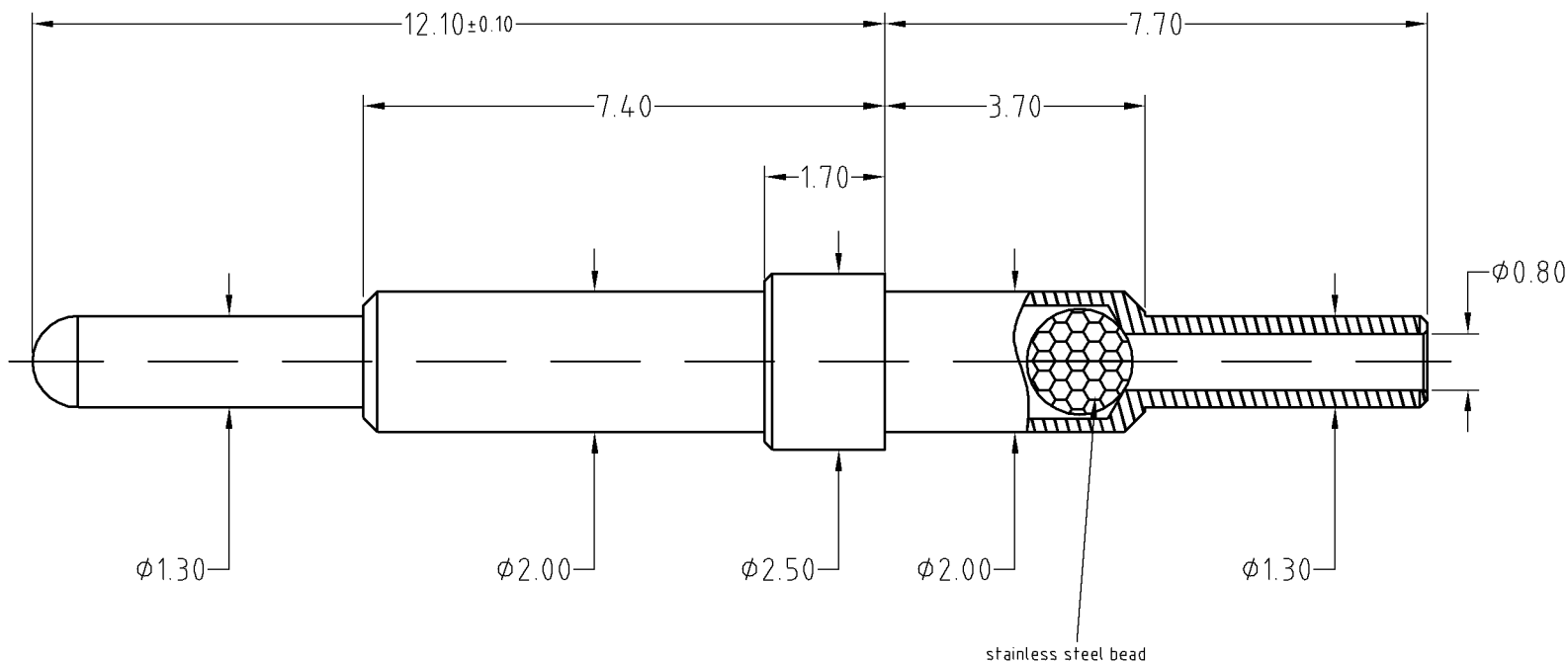

Approve Sign

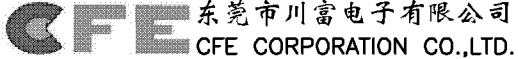

| BOM     |            |     |
|---------|------------|-----|
| Part    | NO.        | Qty |
| Plunger | B534-P1020 | 1   |
| Barrel  | B534-B1020 | 1   |
| Spring  | B534-S1001 | 1   |
| bead    | B534-G1001 | 1   |

|  |       |   |  |   |          |
|--|-------|---|--|---|----------|
| SCALE                                    | 10:1  | UNIT:mm   | THIS DOCUMENT IS THE SOLE PROPERTY OF CFE CORPORATION CO.,LTD., AND SHOULD NOT BE USED IN WHOLE OR IN PART WITHOUT PRIOR WRITTEN PERMISSION. |  <b>东莞市川富电子有限公司</b><br><b>CFE CORPORATION CO.,LTD.</b> |          |
| ANGEL                                    | ±2°   | A4  |  |   |          |
| 0~6                                      | ±0.10 |  | SHEET: 1 of 1  | PART NO.  | BP534.11 |
| 6~30                                     | ±0.20 | DRAW  |  | FILE NAME   | BP534.XX |
| 30~150                                   | ±0.30 | CHECK   |  | TITLE   | Pogo pin |
| GENERAL TOLERANCE UNLESS OTHERWISE NOTED |       | APPRO   |  |   |          |

|              |     |            |             |
|--------------|-----|------------|-------------|
| _____        | A0  | 2015.11.16 | NEW         |
| ECN(DCN) NO. | REV | DATE       | DESCRIPTION |