

1

2

3

4

Note:

Materials:
 .Plunger: Brass 0.075um Au over Ni
 .Barrel: Brass 0.075um Au over Ni
 .Spring: SUS 304 Au

Mechanical:

.Contact force: 300g±20% at 9.0mm working height
 .Max. compression: 8.8mm
 .Life test: 20,000 cycles

Electrical:

.Rated current & voltage: DC 12V; 3A
 .Contact resistance: 50 milliohm Max.

To ensure the best usage, please operate it based on the working height.
 Based on the engineering drawings, shall not exceed the maximum allowed compression.



Approve Sign

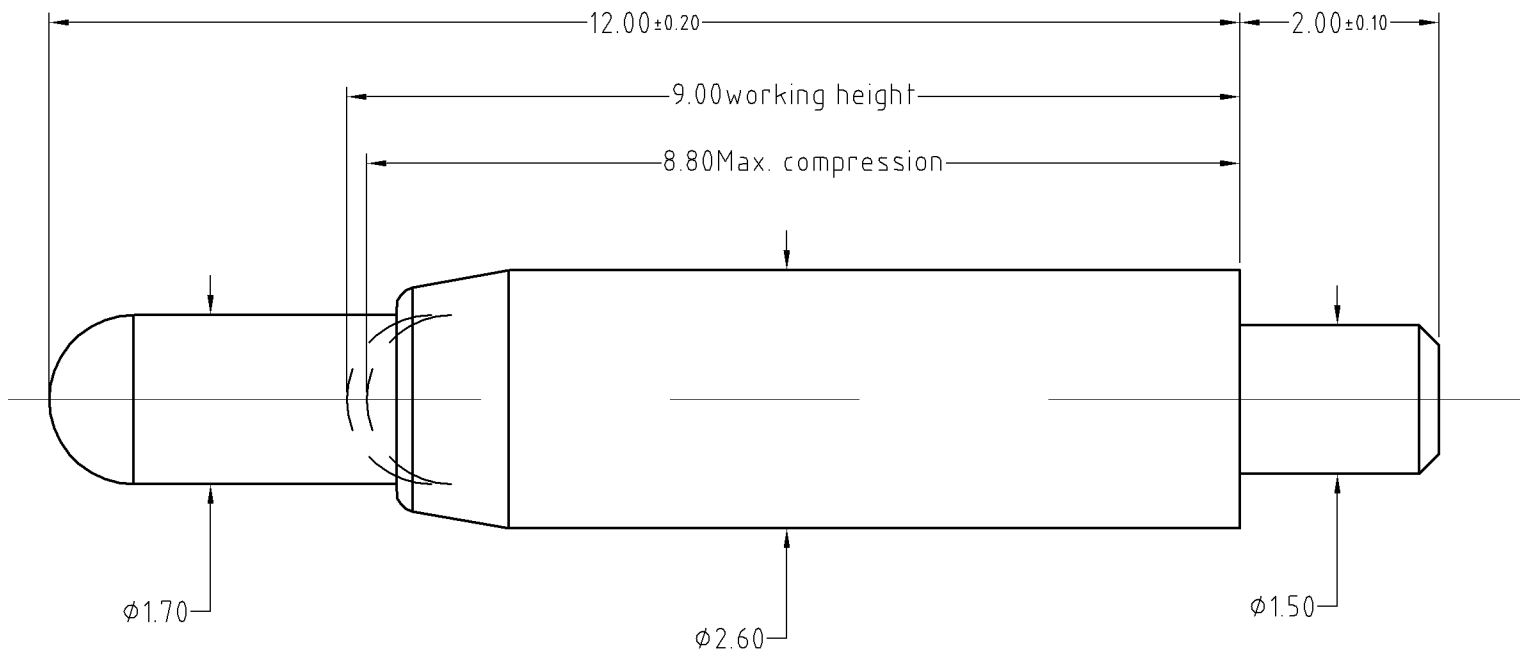

BOM		
Part	NO.	Qty
Plunger	B574-P1003	1
Barrel	B574-B1003	1
Spring	B574-S1001	1

SCALE	10:1	UNIT:mm	THIS DOCUMENT IS THE SOLE PROPERTY OF CFE CORPORATION CO.,LTD., AND SHOULD NOT BE USED IN WHOLE OR IN PART WITHOUT PRIOR WRITTEN PERMISSION.	CFE 东莞市川富电子有限公司 CFE CORPORATION CO.,LTD.
ANGEL	±2°	A4		
0~6	±0.05		SHEET: 1 of 1	
6~30	±0.10	DRAW		PART NO. BP574.11
30~150	±0.15	CHECK		FILE NAME BP574.XX
GENERAL TOLERANCE UNLESS OTHERWISE NOTED		APPRO		TITLE. Pogo pin

	D1	2016.01.20	NEW
	D0	2015.12.18	NEW
ECN(DCN) NO.	REV	DATE	DESCRIPTION