

1

2

3

4

Note:
 Materials:
 .Plunger: Brass 0.25um Au over Ni
 .Barrel: Brass 0.25um Au over Ni
 .Spring: SUS 304 Au
 Mechanical:
 .Contact force: 40g±20g at 1.0mm working stroke
 .Max. stroke: 1.80mm
 .Life test: 20,000 cycles
 Electrical:
 .Rated current & voltage: DC 12V; 3A
 .Contact resistance: 50 milliohm Max.

To ensure the best usage, please operate it based on the working height.
 Based on the engineering drawings, shall not exceed the maximum allowed compression.



Approve Sign

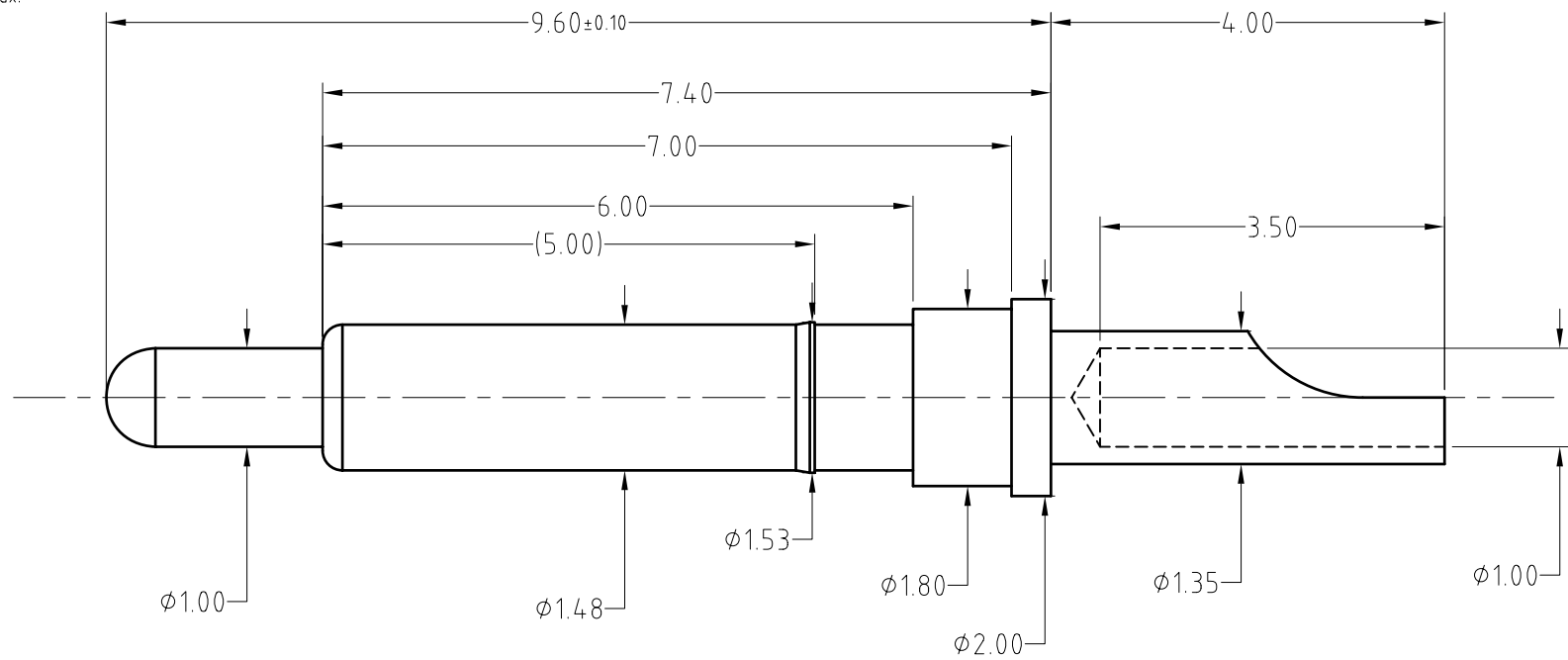

BOM		
Part	NO.	Qty
Plunger	M200-P3010	1
Barrel	B587-B1010	1
Spring	B587-S1001	1

SCALE	10:1	UNIT:mm	THIS DOCUMENT IS THE SOLE PROPERTY OF CFE CORPORATION CO.,LTD., AND SHOULD NOT BE USED IN WHOLE OR IN PART WITHOUT PRIOR WRITTEN PERMISSION.
ANGEL	±2°	A4	
0~6	±0.05		
6~30	±0.10	DRAW	
30~150	±0.15	CHECK	
GENERAL TOLERANCE UNLESS OTHERWISE NOTED		APPRO	

东莞市川富电子有限公司 CFE CORPORATION CO.,LTD.	
PART NO.	BP58711
FILE NAME	BP587XX
TITLE.	Pogo pin

ECN(DCN) NO.	REV	DATE	DESCRIPTION
	A0	2016.11.03	NEW