

Note:
 Materials:
 .Plunger: Brass 0.075um Au over Ni
 .Barrel: Brass 0.075um Au over Ni
 .Spring: SUS 304 Au
 Mechanical:
 .Contact force: 130g±20% at 1.9mm working Stoke
 .Max. Stoke: 2.5mm
 .Life test: 20,000 cycles
 Electrical:
 .Rated current & voltage: DC 12V: 2A
 .Contact resistance: 50 milliohm Max.

To ensure the best usage, please operate it based on the working height.
 Based on the engineering drawings, shall not exceed the maximum allowed compression.



Approve Sign

1.90woking stroke

BOM		
Part	NO.	Qty
Plunger	B851-P1003	1
Barrel	B851-B1003	1
Spring	B851-S1001	1
Plug	B851-W1003	1

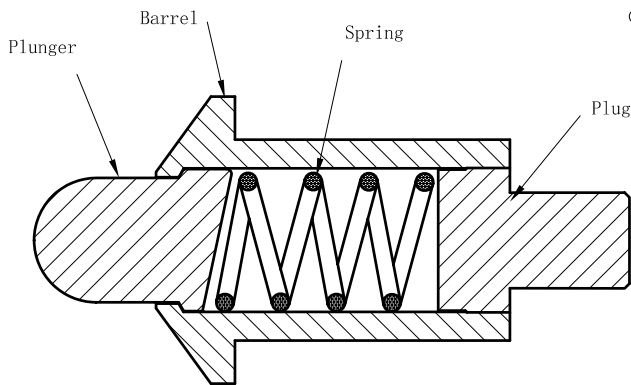
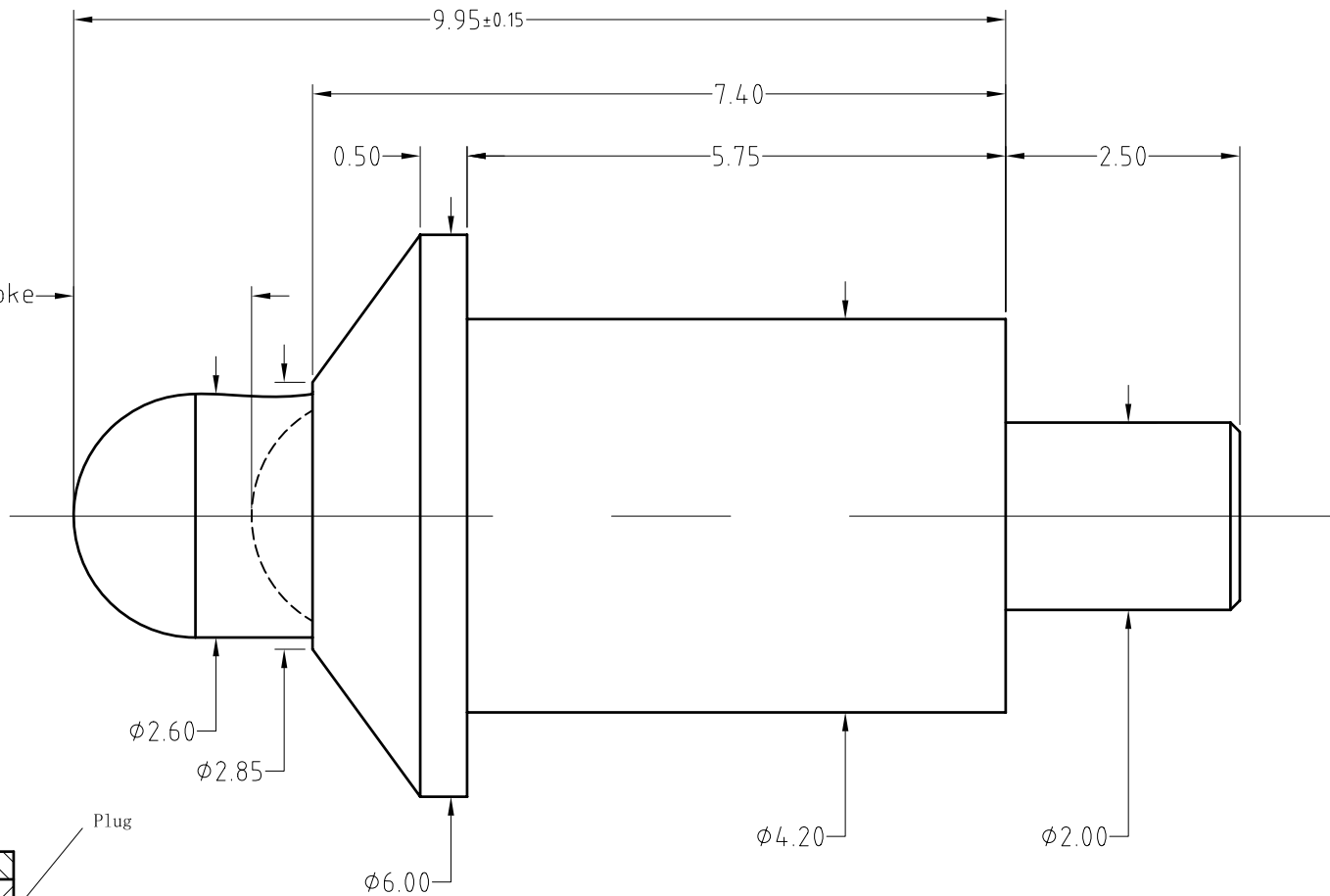

SCALE	10:1	UNIT:mm	THIS DOCUMENT IS THE SOLE PROPERTY OF CFE CORPORATION CO.,LTD., AND SHOULD NOT BE USED IN WHOLE OR IN PART WITHOUT PRIOR WRITTEN PERMISSION.	东莞市川富电子有限公司 CFE CORPORATION CO.,LTD.	
ANGEL	±2°	A4			
0~6	±0.05				SHEET: 1 of 1
6~30	±0.10	DRAW			PART NO. BP85111
30~150	±0.15	CHECK	FILE NAME BP851XX	TITLE. Pogo pin	
GENERAL TOLERANCE UNLESS OTHERWISE NOTED		APPRO			

ECN(DCN) NO.	A0	2017.04.13	NEW
REV	DATE	DESCRIPTION	