

Note:

Mechanical:

.Contact force: 80g±20g at 0.8mm working stroke

.Full stroke:1.00mm

.Life test: 20,000 cycles

Electrical:

.Rated current & voltage: DC 12V; 1A

.Contact resistance: 50 milliohm Max.

100% open & short test.

To ensure the best usage, please operate it based on the working height.  
Based on the engineering drawings, shall not exceed the maximum allowed compression.



Approve Sign

USB

Pogo pin conn

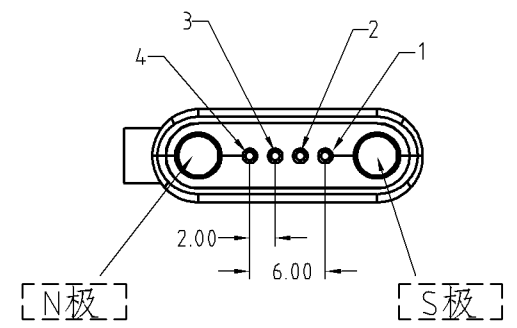
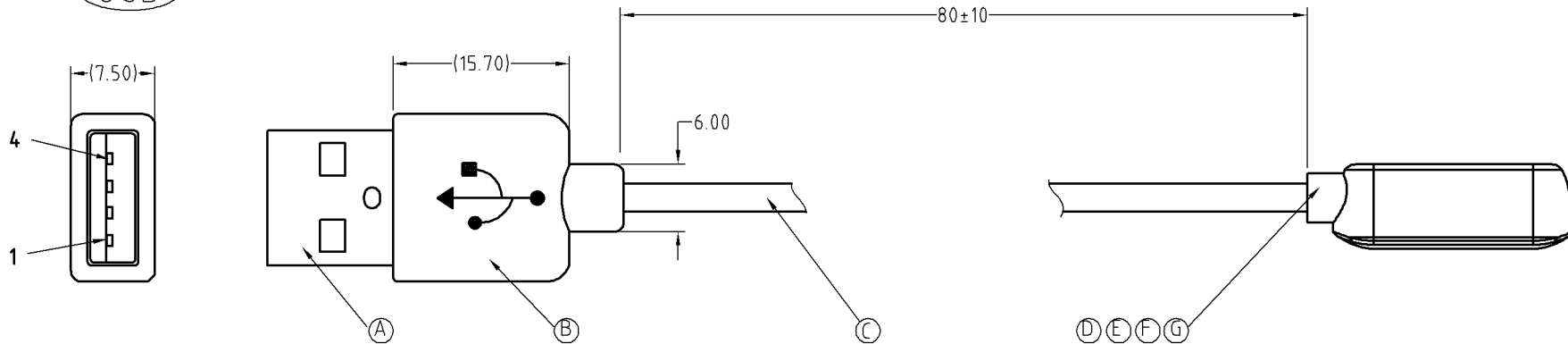

BOM		
序号	规格	数量
G	Pogo pin	4
F	磁铁 N52 表面镀镍	2
E	白色胶芯 ABS	1
D	白色胶芯 ABS	1
C	NO UL 4C 7/0.12 OD:2.5 白色PVC	1
B	白色 PVC RoHS	1
A	USB/AM公焊线式1U" ROHS 盐雾48小时	1

USB→Pogo pin conn	
1_Vcc_1	
2_D-_2	
3_D+_3	
4_GND_4	

SCALE	10:1	UNIT:mm	THIS DOCUMENT IS THE SOLE PROPERTY OF CFE CORPORATION CO.,LTD., AND SHOULD NOT BE USED IN WHOLE OR IN PART WITHOUT PRIOR WRITTEN PERMISSION.	SHEET: 1 of 1		东莞市川富电子有限公司	
ANGEL	±1°	A4				CFE CORPORATION CO.,LTD.	
0~6	±0.10				PART NO.	CM-BP38611-04200H0C	
6~30	±0.15	DRAW			FILE NAME	BP386XX	
30~150	±0.20	CHECK	TITLE.	Pogo pin connector			
GENERAL TOLERANCE UNLESS OTHERWISE NOTED		APPRO					

ECN(DCN) NO.	REV	DATE	DESCRIPTION
	D0	2015.03.10	NEW