

1

2

3

4

Note:

Materials:

.Plunger: Brass 0.50um Au over Ni

.Barrel: Brass 0.50um Au over Ni

.Spring: SUS 304 surface treatment

Mechanical:

.Contact force: 80g±20g at 0.60mm working stroke.

.Max. stroke: 0.9mm

.Life test: 50,000 cycles

Electrical:

.Rated current & voltage: DC 12V; 1A

.Contact resistance: 50 milliohm Max.

Cannot be used as the charging

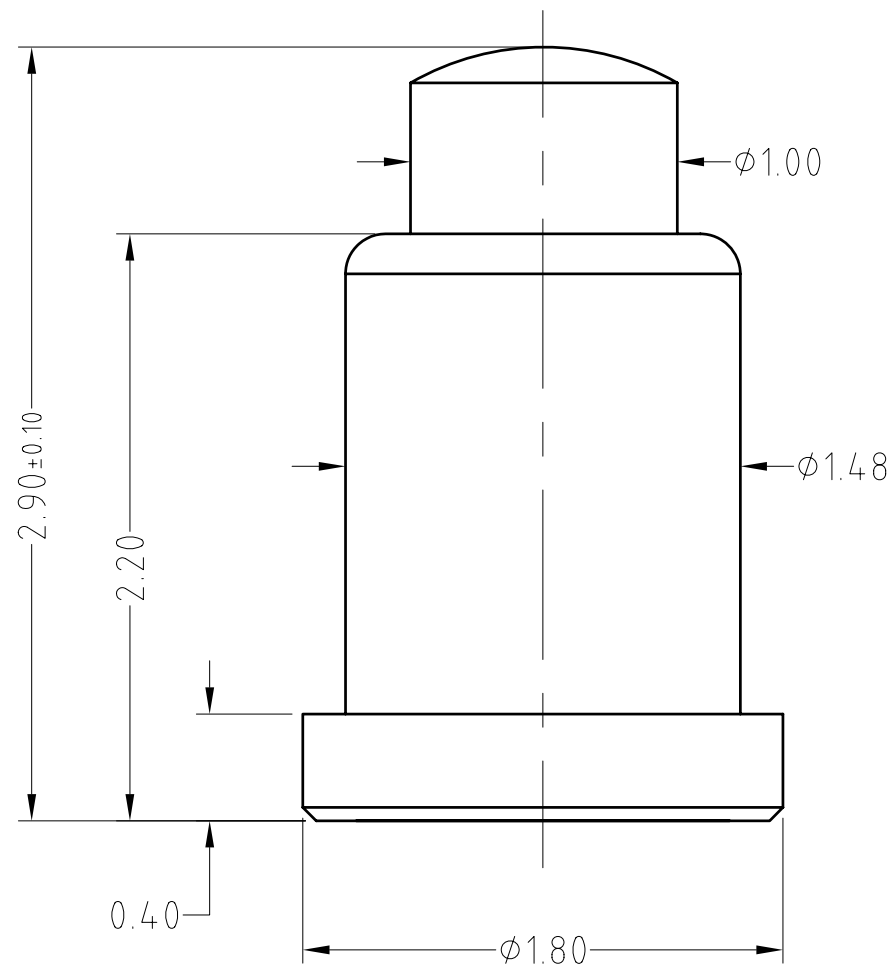

BOM

Part	NO.	Qty
Plunger	B897-P1020	1
Barrel	B897-B1020	1
Spring	M605-S1001	1

SCALE	10:1	UNIT:mm	THIS DOCUMENT IS THE SOLE PROPERTY OF CFE CORPORATION CO.,LTD., AND SHOULD NOT BE USED IN WHOLE OR IN PART WITHOUT PRIOR WRITTEN PERMISSION.		CFE 东莞市川富电子有限公司 CFE CORPORATION CO.,LTD.	
ANGEL	±1°	A4	SHEET: 1 of 1			
0~6	±0.05				PART NO.	BF89711
6~30	±0.10	DRAW			FILE NAME	BF897XX
30~150	±0.15	CHECK			TITLE.	Pogo pin connector
GENERAL TOLERANCE UNLESS OTHERWISE NOTED		APPRO				

	A0	2016.12.05	NEW
ECN(DCN) NO.	REV	DATE	DESCRIPTION