

1

2

3

4

Note:

Materials:

.Plunger: Brass Au over Ni

.Barrel: Brass Au over Ni

.Spring: SUS 304 surface treatment

Mechanical:

.Contact force: 70g±20g at 1.0mm working stroke.

.Max. stroke: 1.40mm

.Life test: 100,000 cycles

Electrical:

.Rated current & voltage: DC 12V; 1A

.Contact resistance: 50 milliohm Max.

Cannot be used as the charging

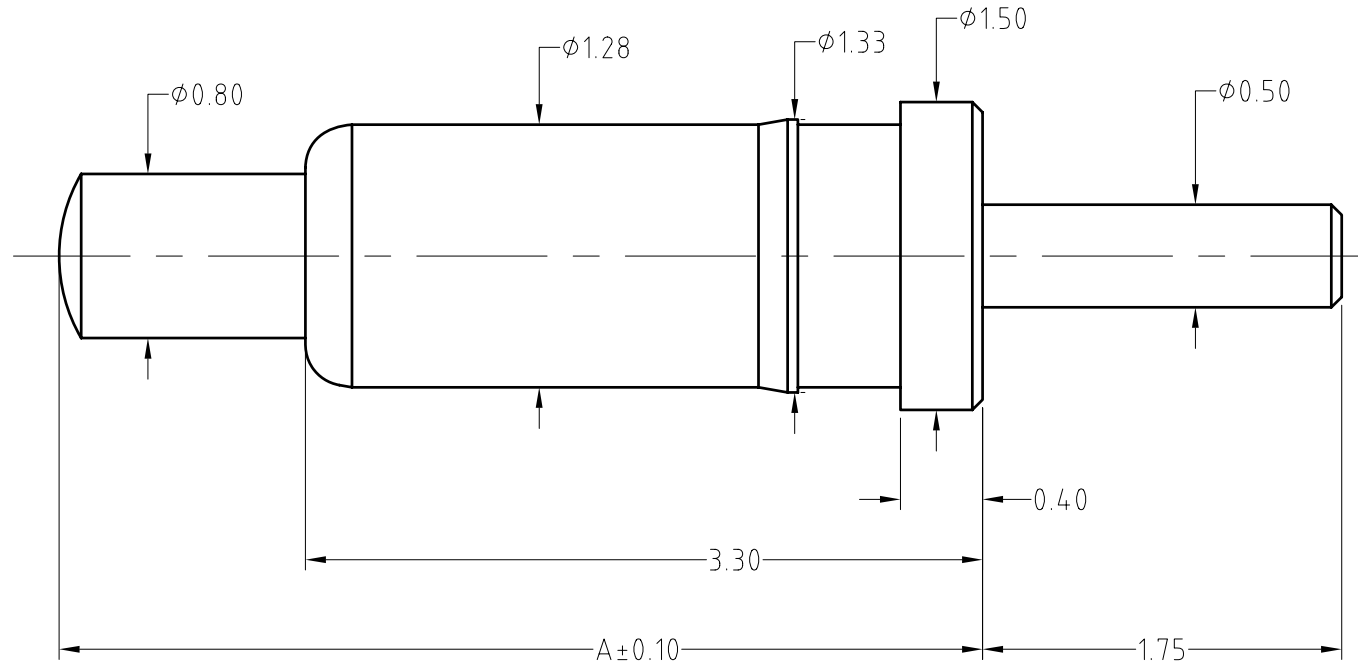

MF809- SS GG			
SS	Total length-A	GG-Plating:	
11	4.50mm	Barrel	Plunger
21	5.00mm	A-0.025um	A-0.025um
		B-0.075um	B-0.075um
		1-0.125um	1-0.125um
		2-0.25um	2-0.25um
		3-0.375um	3-0.375um
		4-0.50um	4-0.50um

Part NO.	Plunger	Spring	Barrel
MP819-11XX	M807-P3XXX	M809-S1001	M819-B1XXX
MP819-21XX	M807-P5XXX	M809-S1001	M819-B1XXX

SCALE	10:1	UNIT:mm	THIS DOCUMENT IS THE SOLE PROPERTY OF CFE CORPORATION CO.,LTD., AND SHOULD NOT BE USED IN WHOLE OR IN PART WITHOUT PRIOR WRITTEN PERMISSION.	CFE 东莞市川富电子有限公司 CFE CORPORATION CO.,LTD.
ANGEL	±1°	A4		
0~6	±0.05		SHEET: 1 of 1	
6~30	±0.10	DRAW		PART NO. MP819-11GG/21GG
30~150	±0.15	CHECK		FILE NAME 8XX
GENERAL TOLERANCE UNLESS OTHERWISE NOTED		APPRO		TITLE. Pogo pin connector

	A0	2016.03.22	NEW
ECN(DCN) NO.	REV	DATE	DESCRIPTION