

1

2

3

4

Note:
 Materials:
 .Plunger: Brass Au over Ni.
 .Spring: SUS surface treatment
 .Barrel: Brass Au over Ni.
 Mechanical:
 .Contact force: 70g±20g at 1.0mm working stroke
 .Full stroke: 1.4mm
 .Life test: 50,000 cycles
 Electrical:
 .Rated current & voltage: DC12V; 3A Max.
 .Contact resistance: 50 milliohm Max.
 Standard tolerances are:
 .Diameters: +/-0.05mm
 .Lengths: +/-0.15mm
 .Angles: +/-2°

A

B

C

D



Approve
 Sign

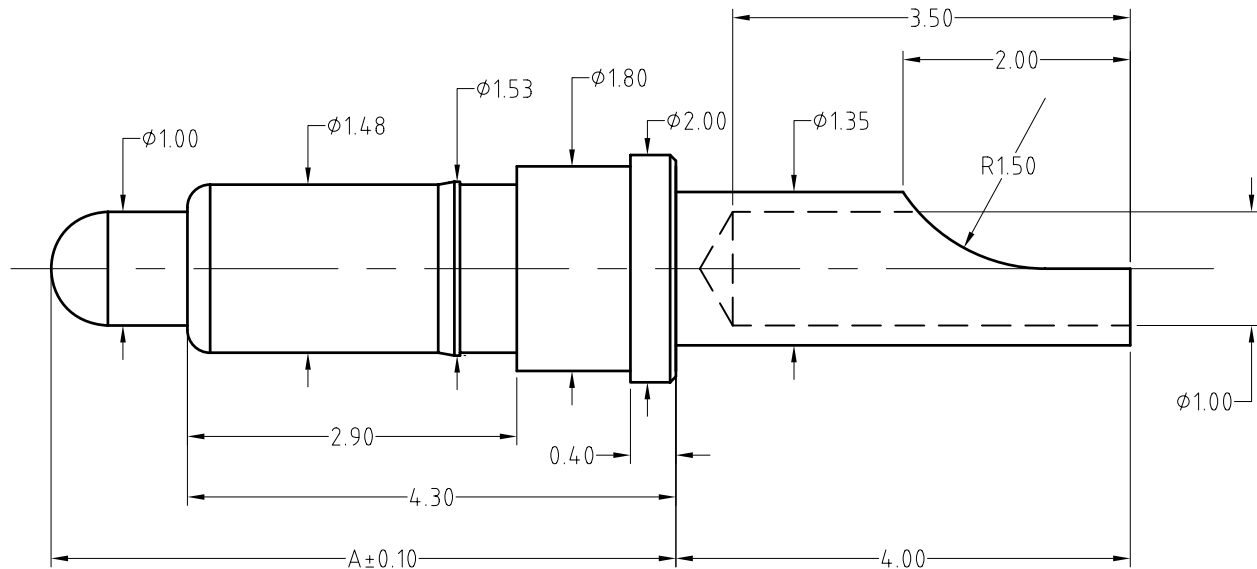

MS230- SS GG			
SS	Total length-A	GG-Plating:	
11	5.50mm	Barrel	Plunger
21	6.00mm	1-0.125um	1-0.125um
		2-0.25um	2-0.25um
		4-0.5um	4-0.5um
	

SCALE	10:1	UNIT:mm	THIS DOCUMENT IS THE SOLE PROPERTY OF CFE CORPORATION CO.,LTD., AND SHOULD NOT BE USED IN WHOLE OR IN PART WITHOUT PRIOR WRITTEN PERMISSION.	东莞市川富电子有限公司 CFE CORPORATION
ANGEL	±1°	A4		
0~6	±0.05		SHEET: 1 of 1	
6~30	±0.10	DRAW		PART NO. MS230-11GG&21GG
30~150	±0.15	CHECK		FILE NAME 230
GENERAL TOLERANCE UNLESS OTHERWISE NOTED		APPRO		TITLE. Pogo pin connector

_____	A0	2014.07.24	NEW
ECN(DCN) NO.	REV	DATE	DESCRIPTION